



SCREW ANCHORS DESIGNED FOR ULTIMATE PERFORMANCE & PRODUCTIVITY

**Supplement to Hilti
North American
Product Technical
Guide Volume 2:
Anchor Fastening
Technical Guide,
Edition 19**

3/8" diameter anchor data for CIP and
CMU is bubbled for convenience

*CIP See Pages 2,3,4,6

*Grout-filled CMU See Pages 2,18,19, 20

KWIK HUS-EZ SCREW ANCHOR

PRODUCT DESCRIPTION

KWIK HUS EZ carbon steel anchors

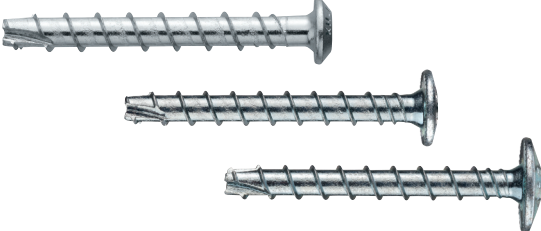
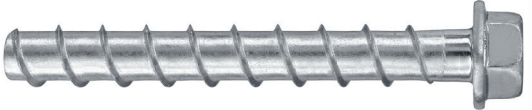
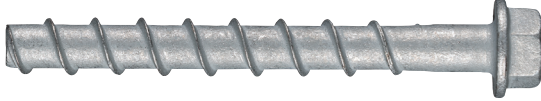
Anchor System	Features and Benefits
 <p>Carbon Steel KH-EZ C 1/4" & 3/8"</p>	<ul style="list-style-type: none"> • OSHA Table 1926.1153 Table 1 complaint installation when installed with Hilti vacuum and DRS system or Hilti SafeSet™ hollow drill bit technology • Easy installation using impact tool or torque wrench
 <p>Carbon Steel 1/4" KH-EZ P, PM, PL</p>	<ul style="list-style-type: none"> • Product and length identification marks helps facilitate quality control after installation • Through fixture installation improves productivity and more accurate installation. • Thread design helps enable quality setting and exceptional load values in wide variety of base material strengths.
 <p>Carbon Steel KH EZ 1/4"-3/4"</p>	<ul style="list-style-type: none"> • 1/4" diameter available in hex head countersunk head and pan head styles. • Anchor is fully removable. • Anchor diameter is same as drill bit diameter. No special diameter bit required. • Suitable for reduced edge distances and spacing.
 <p>Carbon Steel KH-EZ CRC 3/8"-3/4"</p>	<ul style="list-style-type: none"> • Corrosion resistant coating allows for use in outdoor moderate corrosive environments (KH-EZ CRC only). • Installation process allows for adjustability.

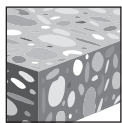

Uncracked concrete

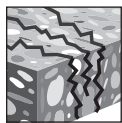

Cracked concrete

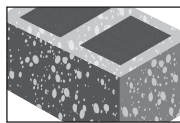

Grout-filled concrete masonry



Seismic Design Categories A-F



SafeSet™ System with Hollow Drill Bit



Profis Anchor design software

Approvals/Listings	
ICC-ES (International Code Council)	ESR-3027 in concrete per ACI 318-14 Ch. 17 / ACI 355.2/ ICC-ES AC193 ESR-3056 in grout-filled CMU per ICC-ES AC106
City of Los Angeles	City of Los Angeles 2017 LABC Supplement (within ESR-3027 and ESR-3056)
Florida Building Code	2017 FBC w/ HVHZ (within ESR-3027 and ESR-3056)
FM (Factory Mutual)	Pipe hanger components for automatic sprinkler systems for KH-EZ I and KH-EZ E



MATERIAL SPECIFICATIONS

Heat treated carbon steel with a minimum zinc coating of 0.0003 inch (8 µm) thick in accordance with DIN EN ISO 4042.

KH-EZ CRC has mechanically deposited zinc coating with a minimum thickness of 0.0021 inch (53 µm) in accordance with ASTM B695, Class 55.

INSTALLATION PARAMETERS

Table 1 - Hilti KH-EZ, KH-EZ P, KH-EZ PM, KH-EZ PL, KH-EZ C and KH-EZ CRC specifications

Setting information	Symbol	Units	Nominal anchor diameter													
			1/4		3/8			1/2			5/8			3/4		
Head style and coating			Hex, P, PM, PL, C head		Hex, C head			Hex, C head (Including CRC)			Hex head (Including CRC)			Hex head (Including CRC)		
Nominal bit diameter	d_{bit}	in.	1/4		3/8			1/2			5/8			3/4		
Minimum nominal embedment	h_{nom}	in.	1-5/8	2-1/2	1-5/8	2-1/8	2-1/2	3-1/4	2-1/4	3	4-1/4	3-1/4	4	5	4	6-1/4
Minimum effective embedment	h_{ef}	in.	1.18	1.92	1.11	1.54	1.86	2.50	1.50	2.16	3.22	2.39	3.03	3.88	2.92	4.84
Minimum hole depth	h_o	in.	2	2-7/8	1-7/8	2-3/8	2-3/4	3-1/2	2-5/8	3-3/8	4-5/8	3-5/8	4-3/8	5-3/8	4-3/8	6-5/8
Minimum fixture hole diameter	d_h	in.	3/8		1/2			5/8			3/4			7/8		
Anchor Length = $h_{nom} + t$	ℓ		See ordering information													
Installation torque concrete ¹	T_{inst}	ft-lb (Nm)	18 (24)	19 (26)	40 (54)			45 (61)			85 (115)			95 ⁴ (129)		
Maximum impact wrench torque rating concrete ²	$T_{impact,max}$	ft-lb (Nm)	157 (213)	157 (213)	450 (610)			437 (586)			450 (610)			590 (800)		
Installation torque masonry KH-EZ (P, PM, PL, C)	T_{inst}	ft-lb (Nm)	21 (28)		22 (30)			34 (46)			38 (52)			70 (95)		
Installation torque masonry for KH-EZ CRC	T_{inst}	ft-lb (Nm)			20 (27)			25 (34)			35 (48)			45 (61)		
Maximum impact wrench torque rating masonry for KH-EZ (P, PM, PL, C) ^{2,3}	$T_{impact,max}$	ft-lb (Nm)	114 (155)		114 (155)			332 (450)			332 (450)			332 (450)		
Maximum impact wrench torque rating masonry for KH-EZ CRC ^{2,3}	$T_{impact,max}$	ft-lb (Nm)			100 (136)			100 (136)			332 (450)			332 (450)		
Wrench size		in.	7/16		9/16			3/4			15/16			1-1/8		

1 T_{inst} is the maximum installation torque that may be applied with a torque wrench.

2 Because of variability in measurement procedures, the published torque of an impact tool may not correlate properly with the above setting torques. Over torquing can damage the anchor and/or reduce its holding capacity.

3 For more information on KWIK HUS-EZ installed in masonry, see ESR-3056 and Design Information for Masonry in this section.

4 Maximum installation torque in concrete for 3/4-in diameter KH-EZ CRC is 85 ft-lbs. (115 Nm).

Figure 1 - Hilti KWIK HUS-EZ specifications

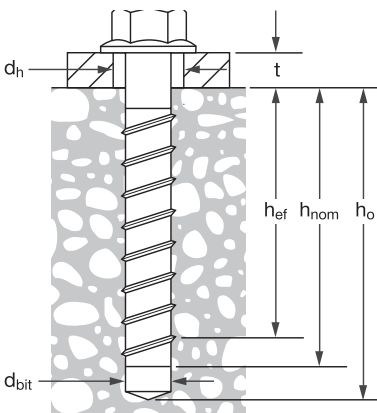

DESIGN INFORMATION IN CONCRETE PER ACI 318

ACI 318-14 Chapter 17 design

The load values contained in this section are Hilti Simplified Design Tables. The load tables in this section were developed using the Strength Design parameters and variables of ESR-3027 and the equations within ACI 318-14 Chapter 17. For a detailed explanation of the Hilti Simplified Design Tables, refer to section 3.1.8 of the North American Product Technical Guide, Volume 2: Anchor Fastening Technical Guide, Edition 19 (PTG Ed. 19). Data tables from ESR-3027 are not contained in this section, but can be found at www.icc-es.org or at www.hilti.com.

Table 2 - Hilti KH-EZ, KH-EZ P, KH-EZ PM, KH-EZ PL, KH-EZ C and KH-EZ CRC design Strength with concrete / pullout failure in uncracked concrete^{1,2,3,4}

Nominal anchor diameter in. (mm)	Nominal Embed. Depth in. (mm)	Tension - ϕN_n				Shear - ϕV_n			
		$f'_c = 2,500$ psi (17.2 MPa) lb (kN)	$f'_c = 3,000$ psi (20.7 MPa) lb (kN)	$f'_c = 4,000$ psi (27.6 MPa) lb (kN)	$f'_c = 6,000$ psi (41.4 MPa) lb (kN)	$f'_c = 2,500$ psi (17.2 MPa) lb (kN)	$f'_c = 3,000$ psi (20.7 MPa) lb (kN)	$f'_c = 4,000$ psi (27.6 MPa) lb (kN)	$f'_c = 6,000$ psi (41.4 MPa) lb (kN)
1/4 (6.4)	1-5/8 (41)	585 (2.6)	620 (2.8)	675 (3.0)	765 (3.4)	1,075 (4.8)	1,180 (5.2)	1,360 (6.0)	1,670 (7.4)
	2-1/2 (64)	1,525 (6.8)	1,670 (7.4)	1,930 (8.6)	2,365 (10.5)	2,235 (9.9)	2,450 (10.9)	2,825 (12.6)	3,460 (15.4)
3/8 (9.5)	1-5/8 (41)	910 (4.0)	1,000 (4.4)	1,155 (5.1)	1,415 (6.3)	980 (4.4)	1,075 (4.8)	1,245 (5.5)	1,520 (6.8)
	2-1/8 (54)	1,490 (6.6)	1,635 (7.3)	1,885 (8.4)	2,310 (10.3)	1,605 (7.1)	1,760 (7.8)	2,030 (9.0)	2,485 (11.1)
	2-1/2 (64)	1,980 (8.8)	2,165 (9.6)	2,505 (11.1)	3,065 (13.6)	2,130 (9.5)	2,335 (10.4)	2,695 (12.0)	3,300 (14.7)
	3-1/4 (83)	3,085 (13.7)	3,375 (15.0)	3,900 (17.3)	4,775 (21.2)	6,640 (29.5)	7,275 (32.4)	8,400 (37.4)	10,290 (45.8)
1/2 (12.7)	2-1/4 (57)	1,645 (7.3)	1,800 (8.0)	2,080 (9.3)	2,550 (11.3)	1,770 (7.9)	1,940 (8.6)	2,240 (10.0)	2,745 (12.2)
	3 (76)	2,785 (12.4)	3,050 (13.6)	3,525 (15.7)	4,315 (19.2)	3,000 (13.3)	3,285 (14.6)	3,795 (16.9)	4,645 (20.7)
	4-1/4 (108)	5,070 (22.6)	5,555 (24.7)	6,415 (28.5)	7,855 (34.9)	10,920 (48.6)	11,965 (53.2)	13,815 (61.5)	16,920 (75.3)
5/8 (15.9)	3-1/4 (83)	3,240 (14.4)	3,550 (15.8)	4,100 (18.2)	5,025 (22.4)	3,490 (15.5)	3,825 (17.0)	4,415 (19.6)	5,410 (24.1)
	4 (102)	4,630 (20.6)	5,070 (22.6)	5,855 (26.0)	7,170 (31.9)	9,970 (44.3)	10,920 (48.6)	12,610 (56.1)	15,445 (68.7)
	5 (127)	6,705 (29.8)	7,345 (32.7)	8,485 (37.7)	10,390 (46.2)	14,445 (64.3)	15,825 (70.4)	18,270 (81.3)	22,380 (99.6)
3/4 (19.1)	4 (102)	4,380 (19.5)	4,795 (21.3)	5,540 (24.6)	6,785 (30.2)	9,430 (41.9)	10,330 (45.9)	11,930 (53.1)	14,610 (65.0)
	6-1/4 (159)	9,345 (41.6)	10,235 (45.5)	11,820 (52.6)	14,475 (64.4)	20,125 (89.5)	22,045 (98.1)	25,455 (113.2)	31,175 (138.7)

Table 3 - Hilti KH-EZ, KH-EZ P, KH-EZ PM, KH-EZ PL, KH-EZ C and KH-EZ CRC design Strength with concrete / pullout failure in cracked concrete^{1,2,3,4,5}

Nominal anchor diameter in. (mm)	Nominal embed. in. (mm)	Tension - ϕN_n				Shear - ϕV_n			
		$f'_c = 2,500$ psi (17.2 MPa) lb (kN)	$f'_c = 3,000$ psi (20.7 MPa) lb (kN)	$f'_c = 4,000$ psi (27.6 MPa) lb (kN)	$f'_c = 6,000$ psi (41.4 MPa) lb (kN)	$f'_c = 2,500$ psi (17.2 MPa) lb (kN)	$f'_c = 3,000$ psi (20.7 MPa) lb (kN)	$f'_c = 4,000$ psi (27.6 MPa) lb (kN)	$f'_c = 6,000$ psi (41.4 MPa) lb (kN)
1/4 (6.4)	1-5/8 (41)	300 (1.3)	315 (1.4)	345 (1.5)	390 (1.7)	765 (3.4)	835 (3.7)	965 (4.3)	1,180 (5.2)
	2-1/2 (64)	760 (3.4)	830 (3.7)	960 (4.3)	1,175 (5.2)	1,585 (7.1)	1,735 (7.7)	2,000 (8.9)	2,450 (10.9)
3/8 (9.5)	1-5/8 (41)	475 (2.1)	520 (2.3)	600 (2.7)	730 (3.2)	695 (3.1)	760 (3.4)	880 (3.9)	1,080 (4.8)
	2-1/8 (54)	1,055 (4.7)	1,155 (5.1)	1,335 (5.9)	1,635 (7.3)	1,135 (5.0)	1,245 (5.5)	1,440 (6.4)	1,760 (7.8)
	2-1/2 (64)	1,400 (6.2)	1,535 (6.8)	1,775 (7.9)	2,170 (9.7)	1,510 (6.7)	1,655 (7.4)	1,910 (8.5)	2,340 (10.4)
	3-1/4 (83)	2,185 (9.7)	2,390 (10.6)	2,765 (12.3)	3,385 (15.1)	4,705 (20.9)	5,155 (22.9)	5,950 (26.5)	7,285 (32.4)
1/2 (12.7)	2-1/4 (57)	1,035 (4.6)	1,185 (5.0)	1,310 (5.8)	1,605 (7.1)	1,115 (5.0)	1,220 (5.4)	1,410 (6.3)	1,725 (7.7)
	3 (76)	1,755 (7.8)	1,920 (8.5)	2,220 (9.9)	2,715 (12.1)	1,890 (8.4)	2,070 (9.2)	2,390 (10.6)	2,925 (13.0)
	4-1/4 (108)	3,190 (14.2)	3,495 (15.5)	4,040 (18.0)	4,945 (22.0)	6,875 (30.6)	7,530 (33.5)	8,695 (38.7)	10,650 (47.4)
5/8 (15.9)	3-1/4 (83)	2,040 (9.1)	2,235 (9.9)	2,580 (11.5)	3,165 (14.1)	2,200 (9.8)	2,410 (10.7)	2,780 (12.4)	3,405 (15.1)
	4 (102)	3,140 (14.0)	3,510 (15.6)	3,845 (17.1)	4,515 (20.1)	6,760 (30.1)	7,560 (33.6)	8,280 (36.8)	9,725 (43.3)
	5 (127)	4,225 (18.8)	4,625 (20.6)	5,340 (23.8)	6,540 (29.1)	9,095 (40.5)	9,965 (44.3)	11,505 (51.2)	14,090 (62.7)
3/4 (19.1)	4 (102)	2,755 (12.3)	3,020 (13.4)	3,485 (15.5)	4,270 (19.0)	5,940 (26.4)	6,505 (28.9)	7,510 (33.4)	9,200 (40.9)
	6-1/4 (159)	5,885 (26.2)	6,445 (28.7)	7,440 (33.1)	9,115 (40.5)	12,670 (56.4)	13,880 (61.7)	16,030 (71.3)	19,630 (87.3)

- 1 See PTG Ed. 19 Section 3.1.8 to convert design strength value to ASD value.
- 2 Linear interpolation between embedment depths and concrete compressive strengths is not permitted.
- 3 Apply spacing, edge distance, and concrete thickness factors in Tables 6 through 15 as necessary. Compare to the steel values in Table 4. The lesser of the values is to be used for the design.
- 4 Tabular values are for normal weight concrete only. For lightweight concrete multiply design strength by λ_a as follows: For sand-lightweight, $\lambda_a = 0.68$. For all-lightweight, $\lambda_a = 0.60$.
- 5 Tabular values are for static loads only. For seismic tension loads, multiply cracked concrete tabular values in tension by the following reduction factors: 1/4-in diameter by 1-5/8-in nominal embedment depth - $a_{N,seis} = 0.60$
All other sizes - $a_{N,seis} = 0.75$
No reduction needed for seismic shear. See PTG Ed. 19 Section 3.1.8 for additional information on seismic applications.

Table 4 - Steel design strength for Hilti KH-EZ, KH-EZ P, KH-EZ PM, KH-EZ PL, KH-EZ C and KH-EZ CRC anchors^{1,2}

Anchor diameter in. (mm)	Nominal embedment depth in. (mm)		Tensile ³ φN _{sa} lb (kN)	Shear ⁴ φV _{sa} lb (kN)	Seismic shear ⁵ φV _{sa,eq} lb (kN)
	1-5/8 (41)	2-1/2 (64)			
1/4 (6.4)	1-5/8 (41)	2-1/2 (64)	3,945 (17.5)	930 (4.1)	835 (3.7)
3/8 (9.5)	1-5/8 (41)	2-1/8 (54)	5,980 (26.6)	2,200 (9.8)	2,200 (9.8)
	2-1/2 (64)	3-1/4 (83)	6,720 (29.9)	3,110 (13.8)	1,865 (8.3)
1/2 (12.7)	2-1/4 (57)	3 (76)	11,780 (52.4)	5,545 (24.7)	3,830 (14.8)
5/8 (15.9)	3-1/4 (83)	4 (102)	15,735 (70.0)	6,735 (30.0)	4,040 (18.0)
3/4 (19.1)	4 (102)	6-1/4 (159)	20,810 (92.6)	9,995 (44.5)	6,935 (30.8)

- 1 See PTG Ed. 19 Section 3.1.8 to convert design strength value to ASD value.
- 2 Hilti KWIK HUS-EZ anchors are to be considered brittle steel elements.
- 3 Tensile φN_{sa} = φ A_{se,N} f_{uta} as noted in ACI 318 Chapter 17.
- 4 Shear values determined by static shear tests with φV_{sa} < φ 0.60 A_{se,V} f_{uta} as noted in ACI 318 Chapter 17.
- 5 Seismic shear values determined by seismic shear tests with φV_{sa} ≤ φ 0.60 A_{se,V} f_{uta} as noted in ACI 318 Chapter 17. See PTG Ed. 19 Section 3.1.8 for additional information on seismic applications.

Figure 2

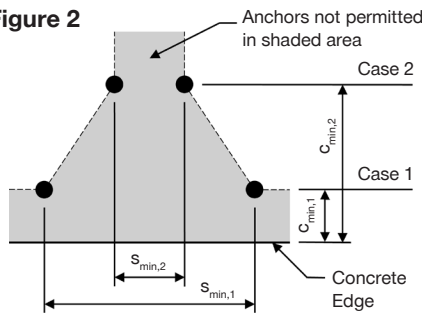

For a specific edge distance, the permitted spacing is calculated as follows:

$$s \geq s_{min,2} + \frac{(s_{min,1} - s_{min,2})}{(c_{min,1} - c_{min,2})} (c - c_{min,2})$$

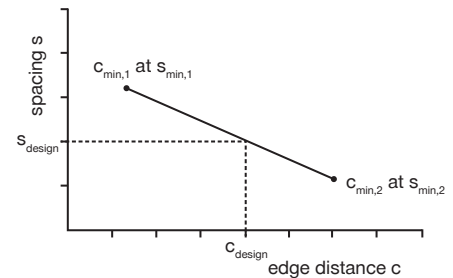

Table 5 - Hilti KH-EZ, KH-EZ P, KH-EZ PM, KH-EZ PL, KH-EZ C and KH-EZ CRC specifications¹

Setting information	Symbol	Units	Nominal anchor diameter													
			1/4	3/8	1/2	5/8	3/4									
Effective minimum embedment	h _{ef}	in.	1.18	1.92	1.11	1.54	1.86	2.50	1.50	2.16	3.22	2.39	3.03	3.88	2.92	4.84
Minimum member thickness	h _{min}	in.	3-1/4	4-1/8	3-1/4	3-2/3	4	4-7/8	4-1/2	4-3/4	6-3/4	5	6	7	6	8-1/8
Case 1	c _{min,1}	in.	1.50						1.75							
	for s _{min,1} ≥	in.	3						4							
Case 2	c _{min,2}	in.	2	2.78	2.63	2.75	2.92	3.75	2.75	3.75	5.25	3.63	4.57	5.81	4.41	7.28
	for s _{min,2} ≥	in.	1.50	2.25						3						

- 1 Linear interpolation is permitted to establish an edge distance and spacing combination between Case 1 and Case 2. Linear interpolation for a specific edge distance c, where c_{min,1} < c < c_{min,2} will determine the permissible spacings.

Table 6 - Load adjustment factors for 1/4-in. diameter Hilti KH-EZ, KH-EZ P, KH-EZ PM, KH-EZ PL and KH-EZ C in uncracked concrete^{1,2}

1/4-in. KH-EZ uncracked concrete		Spacing factor in tension f_{AN}		Edge distance factor in tension f_{RN}		Spacing factor in shear ³ f_{AV}		Edge distance in shear				Conc. thickness factor in shear ⁴ f_{HV}	
								⊥ toward edge f_{RV}		∥ to and away from edge f_{RV}			
Embedment h_{nom}	in. (mm)	1-5/8	2-1/2	1-5/8	2-1/2	1-5/8	2-1/2	1-5/8	2-1/2	1-5/8	2-1/2	1-5/8	2-1/2
		(41)	(64)	(41)	(64)	(41)	(64)	(41)	(64)	(41)	(64)	(41)	(64)
Spacing (s)/edge distance (c _g)/concrete thickness (h) - in. (mm)	1-1/2 (38)	0.71	0.63	0.78	0.65	0.59	0.56	0.40	0.21	0.78	0.42	n/a	n/a
	2 (51)	0.78	0.67	1.00	0.77	0.62	0.58	0.61	0.33	1.00	0.65	n/a	n/a
	2-1/2 (64)	0.85	0.72		0.90	0.65	0.60	0.86	0.46		0.90	n/a	n/a
	3 (76)	0.92	0.76		1.00	0.68	0.62	1.00	0.60		1.00	n/a	n/a
	3-1/4 (83)	0.96	0.78			0.70	0.63		0.68			0.88	n/a
	3-1/2 (89)	0.99	0.80			0.71	0.64		0.76			0.92	n/a
	4 (102)	1.00	0.85			0.74	0.66		0.92			0.98	n/a
	4-1/8 (105)		0.86			0.75	0.66		0.97			1.00	0.81
	4-1/2 (114)		0.89			0.77	0.68		1.00				0.84
	5 (127)		0.93			0.80	0.70						0.89
	5-1/2 (140)		0.98			0.83	0.72						0.93
	6 (152)		1.00			0.86	0.74						0.97
	7 (178)					0.92	0.78						1.00
	8 (203)					0.98	0.82						
9 (229)					1.00	0.86							
10 (254)						0.89							
11 (279)						0.93							
12 (305)						0.97							
14 (356)						1.00							

Table 7 - Load adjustment factors for 1/4-in. diameter Hilti KH-EZ, KH-EZ P, KH-EZ PM, KH-EZ PL and KH-EZ C in cracked concrete^{1,2}

1/4-in. KH-EZ cracked concrete		Spacing factor in tension f_{AN}		Edge distance factor in tension f_{RN}		Spacing factor in shear ³ f_{AV}		Edge distance in shear				Conc. thickness factor in shear ⁴ f_{HV}	
								⊥ toward edge f_{RV}		∥ to and away from edge f_{RV}			
Embedment h_{nom}	in. (mm)	1-5/8	2-1/2	1-5/8	2-1/2	1-5/8	2-1/2	1-5/8	2-1/2	1-5/8	2-1/2	1-5/8	2-1/2
		(41)	(64)	(41)	(64)	(41)	(64)	(41)	(64)	(41)	(64)	(41)	(64)
Spacing (s)/edge distance (c _g)/concrete thickness (h) - in. (mm)	1-1/2 (38)	0.71	0.63	0.88	0.65	0.59	0.56	0.40	0.21	0.80	0.43	n/a	n/a
	2 (51)	0.78	0.67	1.00	0.77	0.62	0.58	0.62	0.33	1.00	0.66	n/a	n/a
	2-1/2 (64)	0.85	0.72		0.90	0.65	0.60	0.87	0.46		0.90	n/a	n/a
	3 (76)	0.92	0.76		1.00	0.68	0.62	1.00	0.60		1.00	n/a	n/a
	3-1/4 (83)	0.96	0.78			0.70	0.63		0.68			0.89	n/a
	3-1/2 (89)	0.99	0.80			0.71	0.64		0.76			0.92	n/a
	4 (102)	1.00	0.85			0.74	0.66		0.93			0.98	n/a
	4-1/8 (105)		0.86			0.75	0.66		0.97			1.00	0.81
	4-1/2 (114)		0.89			0.77	0.68		1.00				0.85
	5 (127)		0.93			0.80	0.70						0.89
	5-1/2 (140)		0.98			0.83	0.72						0.93
	6 (152)		1.00			0.86	0.74						0.98
	7 (178)					0.92	0.78						1.00
	8 (203)					0.98	0.82						
9 (229)					1.00	0.86							
10 (254)						0.90							
11 (279)						0.94							
12 (305)						0.98							
14 (356)						1.00							

- Linear interpolation not permitted.
 - When combining multiple load adjustment factors (e.g. for a 4 anchor pattern in a corner with thin concrete member) the design can become very conservative. To optimize the design, use Hilti PROFIS Engineering software or perform anchor calculation using design equations from ACI 318-14 Chapter 17.
 - Spacing factor reduction in shear, f_{AV} , assumes an influence of a nearby edge. If no edge exists, then $f_{AV} = f_{AN}$.
 - Concrete thickness reduction factor in shear, f_{HV} , assumes an influence of a nearby edge. If no edge exists, then $f_{HV} = 1.0$.
- ☐ If a reduction factor value is in a shaded cell, this indicates that this specific edge distance may not be permitted with a certain spacing (or vice versa). Check with table 5 and figure 2 of this section to calculate permissible edge distance, spacing and concrete thickness combinations.

Table 8 - Load Adjustment Factors for 3/8-in. diameter Hilti KH-EZ, KH-EZ C and KH-EZ CRC in uncracked ^{1,2}

Embedment h_{nom}	in. (mm)	Spacing factor in tension f_{AN}				Edge distance factor in tension f_{RN}				Spacing factor in shear ³ f_{AV}				Edge distance in shear						Conc. thickness factor in shear ⁴ f_{HV}				
														⊥ toward edge f_{RV}			to and away from edge f_{RV}							
		1-5/8 (41)	2-1/8 (54)	2-1/2 (64)	3-1/4 (83)	1-5/8 (41)	2-1/8 (54)	2-1/2 (64)	3-1/4 (83)	1-5/8 (41)	2-1/8 (54)	2-1/2 (64)	3-1/4 (83)	1-5/8 (41)	2-1/8 (54)	2-1/2 (64)	3-1/4 (83)	1-5/8 (41)	2-1/8 (54)	2-1/2 (64)	3-1/4 (83)	1-5/8 (41)	2-1/8 (54)	2-1/2 (64)
1-1/2 (38)	n/a	n/a	n/a	n/a	0.58	0.62	0.63	0.57	n/a	n/a	n/a	n/a	0.49	0.32	0.25	0.08	0.58	0.62	0.50	0.17	n/a	n/a	n/a	n/a
2 (51)	n/a	n/a	n/a	n/a	0.76	0.75	0.75	0.66	n/a	n/a	n/a	n/a	0.75	0.49	0.38	0.13	0.76	0.75	0.75	0.26	n/a	n/a	n/a	n/a
2-1/4 (57)	0.84	0.74	0.70	0.65	0.86	0.82	0.81	0.70	0.65	0.62	0.60	0.55	0.90	0.59	0.46	0.16	0.90	0.82	0.81	0.31	n/a	n/a	n/a	n/a
2-1/2 (64)	0.88	0.77	0.72	0.67	0.95	0.91	0.88	0.75	0.67	0.63	0.61	0.55	1.00	0.69	0.54	0.18	1.00	0.91	0.88	0.37	n/a	n/a	n/a	n/a
3 (76)	0.95	0.82	0.77	0.70	1.00	1.00	1.00	0.85	0.71	0.66	0.63	0.56		0.90	0.71	0.24		1.00	1.00	0.48	n/a	n/a	n/a	n/a
3-1/4 (83)	0.99	0.85	0.79	0.72				0.90	0.72	0.67	0.64	0.57		1.00	0.80	0.27				0.54	0.95	n/a	n/a	n/a
3-1/2 (89)	1.00	0.88	0.81	0.73				0.95	0.74	0.68	0.65	0.58			0.89	0.30				0.61	0.98	n/a	n/a	n/a
4 (102)		0.93	0.86	0.77				1.00	0.78	0.71	0.68	0.59			1.00	0.37				0.74	1.00	0.91	0.84	n/a
4-1/2 (114)		0.99	0.90	0.80					0.81	0.73	0.70	0.60				0.44				0.88			0.89	n/a
4-3/4 (121)		1.00	0.93	0.82					0.83	0.75	0.71	0.60				0.48				0.96			0.91	0.639
5 (127)			0.95	0.83					0.84	0.76	0.72	0.61				0.52				1.00			0.94	0.655
6 (152)			1.00	0.90					0.91	0.81	0.76	0.63				0.68						1.00	0.91	0.718
7 (178)				0.97					0.98	0.86	0.81	0.65				0.86								0.775
8 (203)				1.00					1.00	0.91	0.85	0.67				1.00								0.829
9 (229)										0.97	0.90	0.69												0.879
10 (254)										1.00	0.94	0.71												0.927
11 (279)											0.98	0.74												0.972
12 (305)											1.00	0.76												1.000
14 (356)												0.80												
16 (406)												0.84												
18 (457)												0.89												
20 (508)												0.93												
24 (610)												1.000												

Table 9 - Load Adjustment Factors for 3/8-in. diameter Hilti KH-EZ, KH-EZ C and KH-EZ CRC in cracked ^{1,2}

Embedment h_{nom}	in. (mm)	Spacing factor in tension f_{AN}				Edge distance factor in tension f_{RN}				Spacing factor in shear ³ f_{AV}				Edge distance in shear						Conc. thickness factor in shear ⁴ f_{HV}				
														⊥ toward edge f_{RV}			to and away from edge f_{RV}							
		1-5/8 (41)	2-1/8 (54)	2-1/2 (64)	3-1/4 (83)	1-5/8 (41)	2-1/8 (54)	2-1/2 (64)	3-1/4 (83)	1-5/8 (41)	2-1/8 (54)	2-1/2 (64)	3-1/4 (83)	1-5/8 (41)	2-1/8 (54)	2-1/2 (64)	3-1/4 (83)	1-5/8 (41)	2-1/8 (54)	2-1/2 (64)	3-1/4 (83)	1-5/8 (41)	2-1/8 (54)	2-1/2 (64)
1-1/2 (38)	n/a	n/a	n/a	n/a	0.92	0.74	0.66	0.57	n/a	n/a	n/a	n/a	0.49	0.32	0.25	0.09	0.92	0.64	0.50	0.17	n/a	n/a	n/a	n/a
2 (51)	n/a	n/a	n/a	n/a	1.00	0.90	0.79	0.66	n/a	n/a	n/a	n/a	0.76	0.50	0.39	0.13	1.00	0.90	0.77	0.26	n/a	n/a	n/a	n/a
2-1/4 (57)	0.84	0.74	0.70	0.65	1.00	0.98	0.85	0.70	0.66	0.62	0.60	0.55	0.90	0.59	0.46	0.16	1.00	0.98	0.85	0.31	n/a	n/a	n/a	n/a
2-1/2 (64)	0.88	0.77	0.72	0.67	1.00	1.00	0.92	0.75	0.67	0.63	0.61	0.55	1.00	0.69	0.54	0.18	1.00	1.00	0.92	0.37	n/a	n/a	n/a	n/a
3 (76)	0.95	0.82	0.77	0.70	1.00		1.00	0.85	0.71	0.66	0.63	0.56	1.00	0.91	0.71	0.24	1.00	1.00	1.00	0.48	n/a	n/a	n/a	n/a
3-1/4 (83)	0.99	0.85	0.79	0.72				0.90	0.73	0.67	0.64	0.57		1.00	0.80	0.27				0.55	0.95	n/a	n/a	n/a
3-1/2 (89)	1.00	0.88	0.81	0.73				0.95	0.74	0.68	0.65	0.58			0.90	0.31				0.61	0.98	n/a	n/a	n/a
4 (102)		0.93	0.86	0.77				1.00	0.78	0.71	0.68	0.59			1.00	0.37				0.75	1.00	0.91	0.84	n/a
4-1/2 (114)		0.99	0.90	0.80					0.81	0.73	0.70	0.60				0.44				0.89			0.97	n/a
4-3/4 (121)		1.00	0.93	0.82					0.83	0.75	0.71	0.60				0.48				0.97			1.00	0.64
5 (127)			0.95	0.83					0.85	0.76	0.72	0.61				0.52				1.00			0.94	0.66
6 (152)			1.00	0.90					0.92	0.81	0.77	0.63				0.69						1.00	0.72	
7 (178)				0.97					0.98	0.87	0.81	0.65				0.86								0.78
8 (203)				1.00					1.00	0.92	0.85	0.67				1.00								0.83
9 (229)										0.97	0.90	0.69												0.88
10 (254)											1.00	0.72												0.93
11 (279)												0.99	0.74											0.97
12 (305)												1.00	0.76											1.00
14 (356)												0.80												
16 (406)												0.85												
18 (457)												0.89												
20 (508)												0.93												
24 (610)												1.00												

1 Linear interpolation not permitted.
 2 When combining multiple load adjustment factors (e.g. for a 4 anchor pattern in a corner with thin concrete member) the design can become very conservative. To optimize the design, use Hilti PROFIS Engineering software or perform anchor calculation using design equations from ACI 318-14 Chapter 17.
 3 Spacing factor reduction in shear, f_{AV} , assumes an influence of a nearby edge. If no edge exists, then $f_{AV} = f_{AN}$.
 4 Concrete thickness reduction factor in shear, f_{HV} , assumes an influence of a nearby edge. If no edge exists, then $f_{HV} = 1.0$.
 If a reduction factor value is in a shaded cell, this indicates that this specific edge distance may not be permitted with a certain spacing (or vice versa). Check table 5 and figure 2 of this section to calculate permissible edge distance, spacing and concrete thickness combinations.

Table 10 -Load adjustment factors for 1/2-in. diameter Hilti KH-EZ and KH-EZ CRC in uncracked concrete^{1,2}

1/2-in. KH-EZ uncracked concrete	Spacing factor in tension f_{AN}			Edge distance factor in tension f_{RN}			Spacing factor in shear ³ f_{AV}			Edge distance in shear						Conc. thickness factor in shear ⁴ f_{HV}		
										⊥ toward edge f_{RV}			to and away from edge f_{RV}					
	Embedment h_{nom} in. (mm)	2-1/4 (57)	3 (76)	4-1/4 (108)	2-1/4 (57)	3 (76)	4-1/4 (108)	2-1/4 (57)	3 (76)	4-1/4 (108)	2-1/4 (57)	3 (76)	4-1/4 (108)	2-1/4 (57)	3 (76)	4-1/4 (108)	2-1/4 (57)	3 (76)
1-3/4 (44)	n/a	n/a	n/a	0.68	0.57	0.51	n/a	n/a	n/a	0.40	0.25	0.07	0.68	0.50	0.15	n/a	n/a	n/a
2 (51)	n/a	n/a	n/a	0.75	0.62	0.54	n/a	n/a	n/a	0.48	0.31	0.09	0.75	0.61	0.18	n/a	n/a	n/a
2-1/2 (64)	n/a	n/a	n/a	0.91	0.71	0.60	n/a	n/a	n/a	0.68	0.43	0.13	0.91	0.71	0.25	n/a	n/a	n/a
3 (76)	0.83	0.73	0.66	1.00	0.81	0.66	0.65	0.61	0.55	0.89	0.56	0.17	1.00	0.81	0.33	n/a	n/a	n/a
3-1/2 (89)	0.88	0.77	0.68		0.93	0.73	0.68	0.63	0.56	1.00	0.71	0.21		0.93	0.42	n/a	n/a	n/a
4 (102)	0.94	0.81	0.71		1.00	0.80	0.71	0.65	0.57		0.87	0.26		1.00	0.52	n/a	n/a	n/a
4-1/2 (114)	0.99	0.85	0.73			0.87	0.73	0.67	0.58		1.00	0.31			0.62	0.96	n/a	n/a
4-3/4 (121)	1.00	0.87	0.75			0.91	0.74	0.68	0.58			0.33			0.67	0.99	0.85	n/a
5 (127)		0.89	0.76			0.95	0.76	0.69	0.58			0.36			0.72	1.00	0.87	n/a
6 (152)		0.96	0.81			1.00	0.81	0.73	0.60			0.47			0.95		0.95	n/a
6-3/4 (171)		1.00	0.85				0.85	0.76	0.61			0.57			1.00		1.00	0.68
7 (178)			0.86				0.86	0.77	0.62			0.60						0.69
8 (203)			0.91				0.91	0.80	0.64			0.73						0.73
9 (229)			0.97				0.96	0.84	0.65			0.87						0.78
10 (254)			1.00				1.00	0.88	0.67			1.00						0.82
11 (279)								0.92	0.69									0.86
12 (305)								0.95	0.70									0.90
14 (356)								1.00	0.74									0.97
16 (406)									0.77									1.00
18 (457)									0.80									
20 (508)									0.84									
> 24 (610)									0.91									

Table 11 - Load adjustment factors for 1/2-in. diameter Hilti KH-EZ and KH-EZ CRC in cracked concrete^{1,2}

1/2-in. KH-EZ cracked concrete	Spacing factor in tension f_{AN}			Edge distance factor in tension f_{RN}			Spacing factor in shear ³ f_{AV}			Edge distance in shear						Conc. thickness factor in shear ⁴ f_{HV}		
										⊥ toward edge f_{RV}			to and away from edge f_{RV}					
	Embedment h_{nom} in. (mm)	2-1/4 (57)	3 (76)	4-1/4 (108)	2-1/4 (57)	3 (76)	4-1/4 (108)	2-1/4 (57)	3 (76)	4-1/4 (108)	2-1/4 (57)	3 (76)	4-1/4 (108)	2-1/4 (57)	3 (76)	4-1/4 (108)	2-1/4 (57)	3 (76)
1-3/4 (44)	n/a	n/a	n/a	0.82	0.66	0.55	n/a	n/a	n/a	0.45	0.28	0.08	0.82	0.57	0.17	n/a	n/a	n/a
2 (51)	n/a	n/a	n/a	0.90	0.72	0.58	n/a	n/a	n/a	0.55	0.35	0.10	0.90	0.70	0.21	n/a	n/a	n/a
2-1/2 (64)	n/a	n/a	n/a	1.00	0.83	0.65	n/a	n/a	n/a	0.77	0.49	0.14	1.00	0.83	0.29	n/a	n/a	n/a
3 (76)	0.83	0.73	0.66	1.00	0.94	0.72	0.67	0.62	0.56	1.00	0.64	0.19	1.00	0.94	0.38	n/a	n/a	n/a
3-1/2 (89)	0.88	0.77	0.68		1.00	0.79	0.70	0.64	0.56		0.80	0.24		1.00	0.48	n/a	n/a	n/a
4 (102)	0.94	0.81	0.71		1.00	0.87	0.72	0.66	0.57		0.98	0.29		1.00	0.59	n/a	n/a	n/a
4-1/2 (114)	0.99	0.85	0.73			0.95	0.75	0.69	0.58		1.00	0.35			0.70	1.00	n/a	n/a
4-3/4 (121)	1.00	0.87	0.75			0.99	0.77	0.70	0.59			0.38			0.76		0.88	n/a
5 (127)		0.89	0.76			1.00	0.78	0.71	0.59			0.41			0.82		0.91	n/a
6 (152)		0.96	0.81			1.00	0.84	0.75	0.61			0.54			1.00		0.99	n/a
6-3/4 (171)		1.00	0.85				0.88	0.78	0.62			0.64					1.00	0.70
7 (178)			0.86				0.89	0.79	0.63			0.68						0.72
8 (203)			0.91				0.95	0.83	0.65			0.83						0.77
9 (229)			0.97				1.00	0.87	0.67			0.99						0.81
10 (254)			1.00					0.91	0.68			1.00						0.86
11 (279)								0.95	0.70									0.90
12 (305)								0.99	0.72									0.94
14 (356)								1.00	0.76									1.00
16 (406)									0.79									
18 (457)									0.83									
20 (508)									0.87									
> 24 (610)									0.94									

- Linear interpolation not permitted.
 - When combining multiple load adjustment factors (e.g. for a 4 anchor pattern in a corner with thin concrete member) the design can become very conservative. To optimize the design, use Hilti PROFIS Engineering software or perform anchor calculation using design equations from ACI 318-14 Chapter 17.
 - Spacing factor reduction in shear, f_{AV} , assumes an influence of a nearby edge. If no edge exists, then $f_{AV} = f_{AN}$.
 - Concrete thickness reduction factor in shear, f_{HV} , assumes an influence of a nearby edge. If no edge exists, then $f_{HV} = 1.0$.
- If a reduction factor value is in a shaded cell, this indicates that this specific edge distance may not be permitted with a certain spacing (or vice versa). Check table 5 and figure 2 of this section to calculate permissible edge distance, spacing and concrete thickness combinations.

Table 12 - Load adjustment factors for 5/8-in. diameter Hilti KH-EZ and KH-EZ CRC in uncracked concrete^{1,2}

5/8-in. KH-EZ uncracked concrete		Spacing factor in tension f_{AN}			Edge distance factor in tension f_{RN}			Spacing factor in shear ³ f_{AV}			Edge distance in shear					Conc. thickness factor in shear ⁴ f_{HV}			
											⊥ toward edge f_{RV}			∥ to and away from edge f_{RV}					
Embedment h_{nom}	in. (mm)	3-1/4	4	5	3-1/4	4	5	3-1/4	4	5	3-1/4	4	5	3-1/4	4	5	3-1/4	4	5
		(83)	(102)	(127)	(83)	(102)	(127)	(83)	(102)	(127)	(83)	(102)	(127)	(83)	(102)	(127)	(83)	(102)	(127)
Spacing (s)/edge distance (c_e)/concrete thickness (h) - in. (mm)	1-3/4 (44)	n/a	n/a	n/a	0.622	0.562	0.514	n/a	n/a	n/a	0.235	0.086	0.063	0.470	0.173	0.125	n/a	n/a	n/a
	2 (51)	n/a	n/a	n/a	0.667	0.596	0.540	n/a	n/a	n/a	0.287	0.106	0.076	0.574	0.211	0.153	n/a	n/a	n/a
	2-1/2 (64)	n/a	n/a	n/a	0.762	0.667	0.592	n/a	n/a	n/a	0.401	0.147	0.107	0.762	0.295	0.214	n/a	n/a	n/a
	3 (76)	0.709	0.665	0.629	0.863	0.741	0.648	0.609	0.556	0.545	0.528	0.194	0.141	0.863	0.388	0.281	n/a	n/a	n/a
	3-1/2 (89)	0.744	0.693	0.650	0.969	0.819	0.705	0.627	0.565	0.553	0.665	0.244	0.177	0.969	0.488	0.354	n/a	n/a	n/a
	4 (102)	0.779	0.720	0.672	1.000	0.901	0.764	0.645	0.574	0.560	0.812	0.298	0.216	1.000	0.597	0.433	n/a	n/a	n/a
	4-1/2 (114)	0.814	0.748	0.693		0.987	0.826	0.663	0.584	0.568	0.969	0.356	0.258		0.712	0.516	n/a	n/a	n/a
	5 (127)	0.849	0.775	0.715		1.000	0.890	0.681	0.593	0.575	1.000	0.417	0.302		0.834	0.605	0.852	n/a	n/a
	5-1/2 (140)	0.884	0.803	0.736			0.956	0.700	0.602	0.583		0.481	0.349		0.962	0.698	0.893	n/a	n/a
	6 (152)	0.918	0.830	0.758			1.000	0.718	0.612	0.590		0.548	0.398		1.000	0.795	0.933	0.668	n/a
	7 (178)	0.988	0.885	0.801				0.754	0.630	0.605		0.691	0.501			1.000	1.000	0.722	0.648
	8 (203)	1.000	0.940	0.844				0.790	0.649	0.620		0.844	0.612					0.772	0.693
	9 (229)		0.995	0.887				0.827	0.667	0.635		1.000	0.730					0.818	0.735
	10 (254)		1.000	0.930				0.863	0.686	0.650			0.855					0.863	0.775
	11 (279)			0.973				0.899	0.705	0.665			0.987					0.905	0.813
	12 (305)			1.000				0.935	0.723	0.680			1.000					0.945	0.849
	14 (356)							1.000	0.760	0.710								1.000	0.917
	16 (406)								0.798	0.740									0.980
	18 (457)								0.835	0.770									1.000
	20 (508)								0.872	0.800									
24 (610)								0.947	0.860										
> 30 (762)								1.000	0.951										

Table 13 - Load adjustment factors for 5/8-in. diameter Hilti KH-EZ and KH-EZ CRC in cracked concrete^{1,2}

5/8-in. KH-EZ cracked concrete		Spacing factor in tension f_{AN}			Edge distance factor in tension f_{RN}			Spacing factor in shear ³ f_{AV}			Edge distance in shear					Conc. thickness factor in shear ⁴ f_{HV}			
											⊥ toward edge f_{RV}			∥ to and away from edge f_{RV}					
Embedment h_{nom}	in. (mm)	3-1/4	4	5	3-1/4	4	5	3-1/4	4	5	3-1/4	4	5	3-1/4	4	5	3-1/4	4	5
		(83)	(102)	(127)	(83)	(102)	(127)	(83)	(102)	(127)	(83)	(102)	(127)	(83)	(102)	(127)	(83)	(102)	(127)
Spacing (s)/edge distance (c_e)/concrete thickness (h) - in. (mm)	1-3/4 (44)	n/a	n/a	n/a	0.630	0.565	0.514	n/a	n/a	n/a	0.267	0.098	0.071	0.533	0.196	0.142	n/a	n/a	n/a
	2 (51)	n/a	n/a	n/a	0.676	0.599	0.540	n/a	n/a	n/a	0.326	0.120	0.087	0.652	0.239	0.174	n/a	n/a	n/a
	2-1/2 (64)	n/a	n/a	n/a	0.772	0.670	0.592	n/a	n/a	n/a	0.455	0.167	0.121	0.772	0.335	0.243	n/a	n/a	n/a
	3 (76)	0.709	0.665	0.629	0.873	0.745	0.648	0.618	0.561	0.549	0.599	0.220	0.159	0.873	0.440	0.319	n/a	n/a	n/a
	3-1/2 (89)	0.744	0.693	0.650	0.981	0.824	0.705	0.638	0.571	0.557	0.754	0.277	0.201	0.981	0.554	0.402	n/a	n/a	n/a
	4 (102)	0.779	0.720	0.672	1.000	0.906	0.764	0.658	0.581	0.565	0.922	0.339	0.245	1.000	0.677	0.491	n/a	n/a	n/a
	4-1/2 (114)	0.814	0.748	0.693		0.992	0.826	0.678	0.591	0.574	1.000	0.404	0.293		0.808	0.586	n/a	n/a	n/a
	5 (127)	0.849	0.775	0.715		1.000	0.890	0.697	0.601	0.582	1.000	0.473	0.343		0.946	0.686	0.888	n/a	n/a
	5-1/2 (140)	0.884	0.803	0.736			0.956	0.717	0.611	0.590		0.546	0.396		1.000	0.792	0.932	n/a	n/a
	6 (152)	0.918	0.830	0.758			1.000	0.737	0.621	0.598		0.622	0.451			0.902	0.973	0.697	n/a
	7 (178)	0.988	0.885	0.801				0.776	0.642	0.614		0.784	0.568			1.000	1.000	0.753	0.676
	8 (203)	1.000	0.940	0.844				0.816	0.662	0.631		0.958	0.694					0.805	0.723
	9 (229)		0.995	0.887				0.855	0.682	0.647		1.000	0.828					0.854	0.767
	10 (254)		1.000	0.930				0.895	0.702	0.663			0.970					0.900	0.808
	11 (279)			0.973				0.934	0.723	0.680			1.000					0.944	0.848
	12 (305)			1.000				0.974	0.743	0.696								0.986	0.885
	14 (356)							1.000	0.783	0.729								1.000	0.956
	16 (406)								0.824	0.761									1.000
	18 (457)								0.864	0.794									
	20 (508)								0.905	0.827									
24 (610)								0.986	0.892										
> 30 (762)								1.000	0.990										

1 Linear interpolation not permitted.

2 When combining multiple load adjustment factors (e.g. for a 4 anchor pattern in a corner with thin concrete member) the design can become very conservative. To optimize the design, use Hilti PROFIS Engineering software or perform anchor calculation using design equations from ACI 318-14 Chapter 17.

3 Spacing factor reduction in shear, f_{AV} , assumes an influence of a nearby edge. If no edge exists, then $f_{AV} = f_{AN}$.

4 Concrete thickness reduction factor in shear, f_{HV} , assumes an influence of a nearby edge. If no edge exists, then $f_{HV} = 1.0$.

If a reduction factor value is in a shaded cell, this indicates that this specific edge distance may not be permitted with a certain spacing (or vice versa). Check with table 5 and figure 2 of this section to calculate permissible edge distance, spacing and concrete thickness combinations.

Table 14 - Load adjustment factors for 3/4-in. diameter Hilti KH-EZ and KH-EZ CRC in uncracked concrete^{1,2}

3/4-in. KH-EZ uncracked concrete	Spacing factor in tension f_{AN}		Edge distance factor in tension f_{RN}		Spacing factor in shear ³ f_{AV}		Edge distance in shear				Conc. thickness factor in shear ⁴ f_{HV}		
							⊥ toward edge f_{RV}		to and away from edge f_{RV}				
							4 (102)	6-1/4 (159)	4 (102)	6-1/4 (159)			4 (102)
Embedment h_{nom}	in. (mm)	4 (102)	6-1/4 (159)	4 (102)	6-1/4 (159)	4 (102)	6-1/4 (159)	4 (102)	6-1/4 (159)	4 (102)	6-1/4 (159)	4 (102)	6-1/4 (159)
Spacing (s)/edge distance (c_a)/concrete thickness (h) - in. (mm)	1-3/4 (44)	n/a	n/a	0.57	0.48	n/a	n/a	0.10	0.05	0.19	0.10	n/a	n/a
	2 (51)	n/a	n/a	0.61	0.50	n/a	n/a	0.12	0.06	0.23	0.12	n/a	n/a
	2-1/2 (64)	n/a	n/a	0.68	0.54	n/a	n/a	0.16	0.08	0.33	0.17	n/a	n/a
	3 (76)	0.67	0.60	0.76	0.58	0.56	0.54	0.21	0.11	0.43	0.22	n/a	n/a
	3-1/2 (89)	0.70	0.62	0.84	0.62	0.57	0.55	0.27	0.14	0.54	0.28	n/a	n/a
	4 (102)	0.73	0.64	0.93	0.67	0.58	0.55	0.33	0.17	0.66	0.34	n/a	n/a
	4-1/2 (114)	0.76	0.65	1.00	0.72	0.59	0.56	0.39	0.20	0.79	0.41	n/a	n/a
	5 (127)	0.79	0.67		0.76	0.60	0.56	0.46	0.24	0.92	0.48	n/a	n/a
	5-1/2 (140)	0.81	0.69		0.81	0.61	0.57	0.53	0.28	1.00	0.55	n/a	n/a
	6 (152)	0.84	0.71		0.86	0.62	0.58	0.61	0.31		0.63	0.69	n/a
	7 (178)	0.90	0.74		0.97	0.64	0.59	0.77	0.40		0.79	0.75	n/a
	8 (203)	0.96	0.78		1.00	0.66	0.60	0.94	0.48		0.97	0.80	n/a
	8-1/8 (206)	0.96	0.78			0.66	0.60	0.96	0.50		0.99	0.80	0.65
	9 (229)	1.00	0.81			0.68	0.62	1.00	0.58		1.00	0.85	0.68
	10 (254)		0.84			0.70	0.63		0.68			0.89	0.72
	11 (279)		0.88			0.72	0.64		0.78			0.94	0.75
	12 (305)		0.91			0.74	0.65		0.89			0.98	0.79
	14 (356)		0.98			0.78	0.68		1.00			1.00	0.85
	16 (406)		1.00			0.82	0.71						0.91
	18 (457)					0.86	0.73						0.96
20 (508)					0.90	0.76						1.00	
24 (610)					0.98	0.81							
30 (762)					1.00	0.89							
> 36 (914)						0.96							

Table 15 - Load adjustment factors for 3/4-in. diameter Hilti KH-EZ and KH-EZ CRC in cracked concrete^{1,2}

3/4-in. KH-EZ cracked concrete	Spacing factor in tension f_{AN}		Edge distance factor in tension f_{RN}		Spacing factor in shear ³ f_{AV}		Edge distance in shear				Conc. thickness factor in shear ⁴ f_{HV}		
							⊥ toward edge f_{RV}		to and away from edge f_{RV}				
							4 (102)	6-1/4 (159)	4 (102)	6-1/4 (159)			4 (102)
Embedment h_{nom}	in. (mm)	4 (102)	6-1/4 (159)	4 (102)	6-1/4 (159)	4 (102)	6-1/4 (159)	4 (102)	6-1/4 (159)	4 (102)	6-1/4 (159)	4 (102)	6-1/4 (159)
Spacing (s)/edge distance (c_a)/concrete thickness (h) - in. (mm)	1-3/4 (44)	n/a	n/a	0.57	0.48	n/a	n/a	0.11	0.06	0.22	0.11	n/a	n/a
	2 (51)	n/a	n/a	0.61	0.50	n/a	n/a	0.13	0.07	0.27	0.14	n/a	n/a
	2-1/2 (64)	n/a	n/a	0.68	0.54	n/a	n/a	0.19	0.10	0.37	0.19	n/a	n/a
	3 (76)	0.67	0.60	0.76	0.58	0.57	0.54	0.24	0.13	0.49	0.25	n/a	n/a
	3-1/2 (89)	0.70	0.62	0.85	0.63	0.58	0.55	0.31	0.16	0.61	0.32	n/a	n/a
	4 (102)	0.73	0.64	0.93	0.67	0.59	0.56	0.38	0.19	0.75	0.39	n/a	n/a
	4-1/2 (114)	0.76	0.65	1.00	0.72	0.60	0.56	0.45	0.23	0.90	0.46	n/a	n/a
	5 (127)	0.79	0.67		0.77	0.61	0.57	0.52	0.27	1.00	0.54	n/a	n/a
	5-1/2 (140)	0.81	0.69		0.81	0.62	0.58	0.60	0.31		0.63	n/a	n/a
	6 (152)	0.84	0.71		0.87	0.63	0.58	0.69	0.36		0.71	0.72	n/a
	7 (178)	0.90	0.74		0.97	0.65	0.60	0.87	0.45		0.90	0.78	n/a
	8 (203)	0.96	0.78		1.00	0.67	0.61	1.00	0.55		1.00	0.83	n/a
	8-1/8 (206)	0.96	0.78			0.68	0.61		0.56			0.84	0.67
	9 (229)	1.00	0.81			0.70	0.63		0.66			0.88	0.71
	10 (254)		0.84			0.72	0.64		0.77			0.93	0.75
	11 (279)		0.88			0.74	0.65		0.89			0.98	0.78
	12 (305)		0.91			0.76	0.67		1.00			1.00	0.82
	14 (356)		0.98			0.80	0.70						0.89
	16 (406)		1.00			0.85	0.72						0.95
	18 (457)					0.89	0.75						1.00
20 (508)					0.93	0.78							
24 (610)					1.00	0.84							
30 (762)						0.92							
> 36 (914)						1.00							

1 Linear interpolation not permitted.
 2 When combining multiple load adjustment factors (e.g. for a 4 anchor pattern in a corner with thin concrete member) the design can become very conservative. To optimize the design, use Hilti PROFIS Engineering software or perform anchor calculation using design equations from ACI 318-14 Chapter 17.
 3 Spacing factor reduction in shear, f_{AV} assumes an influence of a nearby edge. If no edge exists, then $f_{AV} = f_{AN}$.
 4 Concrete thickness reduction factor in shear, f_{HV} assumes an influence of a nearby edge. If no edge exists, then $f_{HV} = 1.0$.
 If a reduction factor value is in a shaded cell, this indicates that this specific edge distance may not be permitted with a certain spacing (or vice versa). Check with table 5 and figure 2 of this section to calculate permissible edge distance, spacing and concrete thickness combinations.

Table 16 - Hilti KH-EZ, KH-EZ P, KH-EZ PM, KH-EZ PL, KH-EZ C and KH-EZ CRC in the soffit of uncracked lightweight concrete over metal deck^{1,2,3,4,5,6}

Nominal anchor diameter in.	Nominal embedment in. (mm)	Installation in lower flute				Installation in upper flute			
		Tension - ϕN_n		Shear - ϕV_n		Tension - ϕN_n		Shear - ϕV_n	
		$f'_c = 3,000$ psi lb (kN)	$f'_c = 4,000$ psi lb (kN)	$f'_c = 3,000$ psi lb (kN)	$f'_c = 4,000$ psi lb (kN)	$f'_c = 3,000$ psi lb (kN)	$f'_c = 4,000$ psi lb (kN)	$f'_c = 3,000$ psi lb (kN)	$f'_c = 4,000$ psi lb (kN)
1/4	1-5/8 (41)	545 (2.4)	595 (2.6)	725 (3.2)	725 (3.2)	670 (3.0)	730 (3.2)	725 (3.2)	725 (3.2)
	2-1/2 (64)	1,220 (5.4)	1,410 (6.3)	1,325 (5.9)	1,325 (5.9)	1,275 (5.7)	1,470 (6.5)	1,960 (8.7)	1,960 (8.7)
3/8	1-5/8 (41)	845 (3.8)	975 (4.3)	905 (4.0)	905 (4.0)	970 (4.3)	1,120 (5.0)	2,200 (9.8)	2,200 (9.8)
	2-1/2 (64)	1,455 (6.5)	1,680 (7.5)	905 (4.0)	905 (4.0)	1,900 (8.5)	2,195 (9.8)	3,655 (16.3)	3,655 (16.3)
	3-1/4 (83)	2,550 (11.3)	2,945 (13.1)	2,165 (9.6)	2,165 (9.6)	n/a	n/a	n/a	n/a
1/2	2-1/4 (57)	850 (3.8)	980 (4.4)	965 (4.3)	965 (4.3)	905 (4.0)	1,045 (4.6)	4,710 (21.0)	4,710 (21.0)
	3 (76)	1,990 (8.9)	2,300 (10.2)	1,750 (7.8)	1,750 (7.8)	n/a	n/a	n/a	n/a
	4-1/4 (108)	3,485 (15.5)	4,025 (17.9)	2,155 (9.6)	2,155 (9.6)	n/a	n/a	n/a	n/a
5/8	3-1/4 (83)	2,715 (12.1)	3,135 (13.9)	2,080 (9.3)	2,080 (9.3)	n/a	n/a	n/a	n/a
	5 (127)	6,170 (27.4)	7,125 (31.7)	2,515 (11.2)	2,515 (11.2)	n/a	n/a	n/a	n/a
3/4	4 (102)	2,715 (12.1)	3,135 (13.9)	2,255 (10.0)	2,255 (10.0)	n/a	n/a	n/a	n/a

Table 17 - Hilti KH-EZ, KH-EZ P, KH-EZ PM, KH-EZ PL, KH-EZ C and KH-EZ CRC in the soffit of cracked lightweight concrete over metal deck^{1,2,3,4,5,6}

Nominal anchor diameter in.	Nominal embedment in. (mm)	Installation in lower flute				Installation in upper flute			
		Tension - ϕN_n ⁷		Shear - ϕV_n ⁸		Tension - ϕN_n ⁷		Shear - ϕV_n ⁸	
		$f'_c = 3,000$ psi lb (kN)	$f'_c = 4,000$ psi lb (kN)	$f'_c = 3,000$ psi lb (kN)	$f'_c = 4,000$ psi lb (kN)	$f'_c = 3,000$ psi lb (kN)	$f'_c = 4,000$ psi lb (kN)	$f'_c = 3,000$ psi lb (kN)	$f'_c = 4,000$ psi lb (kN)
1/4	1-5/8 (41)	280 (1.2)	305 (1.4)	725 (3.2)	725 (3.2)	340 (1.5)	370 (1.6)	725 (3.2)	725 (3.2)
	2-1/2 (64)	605 (2.7)	700 (3.1)	1,325 (5.9)	1,325 (5.9)	635 (2.8)	735 (3.3)	1,960 (8.7)	1,960 (8.7)
3/8	1-5/8 (41)	525 (2.3)	605 (2.7)	905 (4.0)	905 (4.0)	770 (3.4)	890 (4.0)	2,200 (9.8)	2,200 (9.8)
	2-1/2 (64)	1,035 (4.6)	1,195 (5.3)	905 (4.0)	905 (4.0)	1,345 (6.0)	1,555 (6.9)	3,655 (16.3)	3,655 (16.3)
	3-1/4 (83)	1,805 (8.0)	2,085 (9.3)	2,165 (9.6)	2,165 (9.6)	n/a	n/a	n/a	n/a
1/2	2-1/4 (57)	535 (2.4)	620 (2.8)	965 (4.3)	965 (4.3)	640 (2.8)	740 (3.3)	4,710 (21.0)	4,710 (21.0)
	3 (76)	1,255 (5.6)	1,450 (6.4)	1,750 (7.8)	1,750 (7.8)	n/a	n/a	n/a	n/a
	4-1/4 (108)	2,195 (9.8)	2,535 (11.3)	2,155 (9.6)	2,155 (9.6)	n/a	n/a	n/a	n/a
5/8	3-1/4 (83)	1,710 (7.6)	1,975 (8.8)	2,080 (9.3)	2,080 (9.3)	n/a	n/a	n/a	n/a
	5 (127)	3,885 (17.3)	4,485 (20.0)	2,515 (11.2)	2,515 (11.2)	n/a	n/a	n/a	n/a
3/4	4 (102)	1,710 (7.6)	1,975 (8.8)	2,255 (10.0)	2,255 (10.0)	n/a	n/a	n/a	n/a

- 1 See PTG Ed. 19 Section 3.1.8 to convert design strength value to ASD value.
- 2 Linear interpolation between embedment depths and concrete compressive strengths is not permitted.
- 3 Tabular value is for one anchor per flute. Minimum spacing along the length of the flute is $3 \times h_{nom}$ (nominal embedment).
- 4 Tabular values are lightweight concrete and no additional reduction factor is needed.
- 5 No additional reduction factors for spacing or edge distance need to be applied.
- 6 Comparison to steel values in table 4 is not required. Values in tables 16 and 17 control.
- 7 Tabular values are for static loads only. Seismic design is not permitted for uncracked concrete. For seismic tension loads, multiply cracked concrete tabular values in tension only by $\alpha_{N,seis} = 0.75$.
See PTG Ed. 19 Section 3.1.8 for additional information on seismic applications.
- 8 For the following anchor sizes, an additional factor for seismic shear must be applied to the cracked concrete tabular values for seismic conditions:
 1/4-inch diameter - $\alpha_{V,seis} = 0.75$
 3/8-inch diameter - $\alpha_{V,seis} = 0.60$
 1/2-inch diameter - $\alpha_{V,seis} = 0.60$
 5/8-inch diameter - $\alpha_{V,seis} = 0.60$
 3/4-inch diameter - $\alpha_{V,seis} = 0.70$

Figure 3 – Installation of Hilti KH-EZ, KH-EZ P, KH-EZ PM, KH-EZ PL, KH-EZ C and KH-EZ CRC in soffit of concrete over steel deck floor and roof assemblies¹

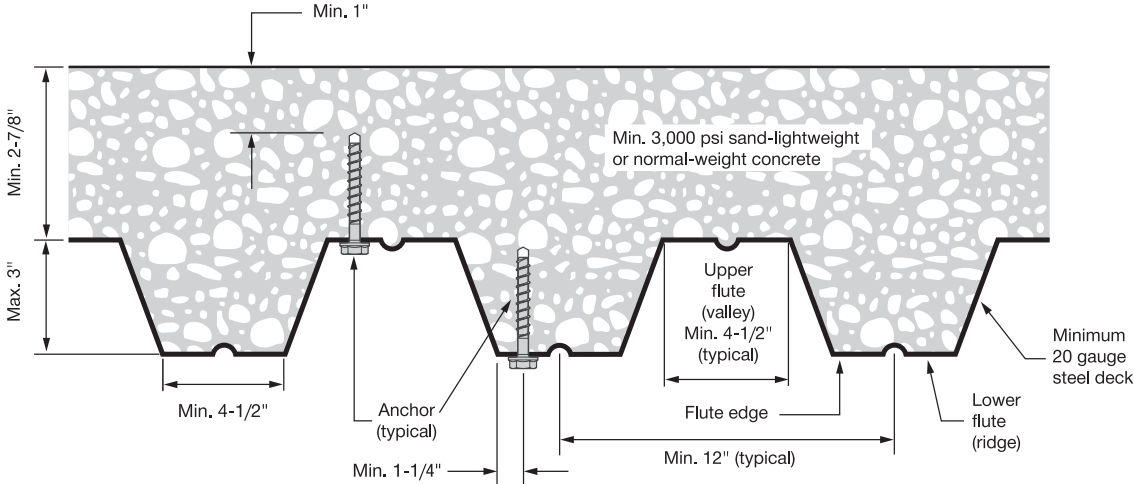

1 Anchors may be placed in the upper or lower flute of the steel deck profile provided the minimum concrete cover above the drilled hole is satisfied. Anchors in the lower flute may be installed with a maximum 1-inch offset in either direction from the center of the flute. The offset distance may be increased proportionally for profiles with lower flute widths greater than those shown provided the minimum lower flute edge distance is also satisfied.

Figure 4 – Installation of Hilti KH-EZ, KH-EZ P, KH-EZ PM, KH-EZ PL, KH-EZ C and KH-EZ CRC on the top of sand-lightweight concrete over metal floor and roof assemblies

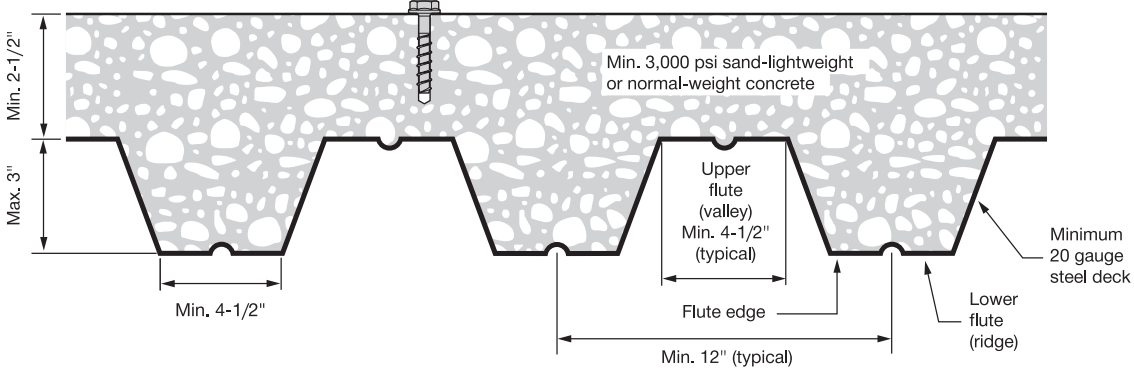

Table 18 - Hilti KH-EZ, KH-EZ P, KH-EZ PM, KH-EZ PL, KH-EZ C and KH-EZ CRC in the top of uncracked concrete over metal deck^{1,2,3,4,5}

Nominal anchor diameter in.	Nominal embedment depth in. (mm)	Tension - ϕN_n		Shear - ϕV_n	
		$f'_c = 3,000$ psi (20.7 MPa) lb (kN)	$f'_c = 4,000$ psi (27.6 MPa) lb (kN)	$f'_c = 3,000$ psi (20.7 MPa) lb (kN)	$f'_c = 4,000$ psi (27.6 MPa) lb (kN)
1/4	1-5/8 (41)	620 (2.8)	675 (3.0)	1,180 (5.2)	1,360 (6.0)
3/8	1-5/8 (41)	1,000 (4.4)	1,155 (5.1)	1,075 (4.8)	1,245 (5.5)

Table 19 - Hilti KH-EZ, KH-EZ P, KH-EZ PM, KH-EZ PL, KH-EZ C and KH-EZ CRC in the top of cracked concrete over metal deck^{1,2,3,4,5}

Nominal anchor diameter in.	Nominal embed. depth in. (mm)	Tension - ϕN_n		Shear - ϕV_n	
		$f'_c = 3,000$ psi (20.7 MPa) lb (kN)	$f'_c = 4,000$ psi (27.6 MPa) lb (kN)	$f'_c = 3,000$ psi (20.7 MPa) lb (kN)	$f'_c = 4,000$ psi (27.6 MPa) lb (kN)
1/4	1-5/8 (41)	315 (1.4)	345 (1.5)	835 (3.7)	965 (4.3)
3/8	1-5/8 (41)	520 (2.3)	600 (2.7)	760 (3.4)	880 (3.9)

- See PTG Ed. 19 Section 3.1.8 to convert design strength value to ASD value.
- Linear interpolation between embedment depths and concrete compressive strengths is not permitted.
- Apply spacing, edge distance, and concrete thickness factors in tables 20 and 21 as necessary. Compare to the steel values in table 4. The lesser of the values is to be used for the design.
- Tabular values are for normal weight concrete only. For lightweight concrete multiply design strength by λ_a as follows:
for sand-lightweight, $\lambda_a = 0.68$; for all-lightweight, $\lambda_a = 0.60$
- Tabular values are for static loads only. Seismic design is not permitted for uncracked concrete. For seismic tension loads, multiply cracked concrete tabular values in tension by the following reduction factors:
1/4-inch diameter - $\alpha_{N,seis} = 0.60$
3/8-inch diameter - $\alpha_{N,seis} = 0.75$.
No reduction needed for seismic shear. See PTG Ed. 19 Section 3.1.8 for additional information on seismic applications.

Table 20 - Load adjustment factors for Hilti KH-EZ, KH-EZ P, KH-EZ PM, KH-EZ PL, KH-EZ C and KH-EZ CRC in the top of uncracked concrete over metal deck^{1,2}

1/4-in. and 3/8-in. KH-EZ uncracked concrete over metal deck		Spacing factor in tension f_{AN}		Edge distance factor in tension f_{RN}		Spacing factor in shear ³ f_{AV}		Edge distance in shear				Conc. thickness factor in shear ⁴ f_{HV}	
								⊥ toward edge f_{RV}		∥ to and away from edge f_{RV}			
Anchor diameter d_a	in. (mm)	1/4 (6.4)	3/8 (9.5)	1/4 (6.4)	3/8 (9.5)	1/4 (6.4)	3/8 (9.5)	1/4 (6.4)	3/8 (9.5)	1/4 (6.4)	3/8 (9.5)	1/4 (6.4)	3/8 (9.5)
Nominal embed. h_{nom}	in. (mm)	1-5/8 (41)	1-5/8 (41)	1-5/8 (41)	1-5/8 (41)	1-5/8 (41)	1-5/8 (41)	1-5/8 (41)	1-5/8 (41)	1-5/8 (41)	1-5/8 (41)	1-5/8 (41)	1-5/8 (41)
Spacing (s)/edge distance (c _s)/concrete thickness (h) - in. (mm)	1-3/4 (44)	n/a	n/a	0.44	0.58	n/a	n/a	0.44	0.58	0.44	0.58	n/a	n/a
	2 (51)	n/a	n/a	0.50	0.67	n/a	n/a	0.50	0.67	0.50	0.67	n/a	n/a
	2-1/2 (64)	n/a	n/a	0.63	0.83	n/a	n/a	0.63	0.83	0.63	0.83	0.78	0.83
	3 (76)	0.92	0.95	0.75	1.00	0.68	0.71	0.75	1.00	0.75	1.00	0.85	0.91
	3-1/4 (83)	0.96	0.99	0.81		0.70	0.72	0.81		0.81			
	3-1/2 (89)	0.99	1.00	0.88		0.71	0.74	0.88		0.88			
	4 (102)	1.00		1.00		0.74	0.78	1.00		1.00			
	4-1/2 (114)					0.77	0.81						
	5 (127)					0.80	0.84						
	5-1/2 (140)					0.83	0.88						
	6 (152)					0.86	0.91						
	6-1/2 (165)					0.89	0.95						
	7 (178)					0.92	0.98						
7-1/2 (191)					0.95	1.00							
8 (203)					0.98								
9 (229)					1.00								

Table 21 - Load adjustment factors for Hilti KH-EZ, KH-EZ P, KH-EZ PM, KH-EZ PL, KH-EZ C and KH-EZ CRC in the top of cracked concrete over metal deck^{1,2}

1/4-in. and 3/8-in. KH-EZ cracked concrete over metal deck		Spacing factor in tension f_{AN}		Edge distance factor in tension f_{RN}		Spacing factor in shear ³ f_{AV}		Edge distance in shear				Conc. thickness factor in shear ⁴ f_{HV}	
								⊥ toward edge f_{RV}		∥ to and away from edge f_{RV}			
Anchor diameter d_a	in. (mm)	1/4 (6.4)	3/8 (9.5)	1/4 (6.4)	3/8 (9.5)	1/4 (6.4)	3/8 (9.5)	1/4 (6.4)	3/8 (9.5)	1/4 (6.4)	3/8 (9.5)	1/4 (6.4)	3/8 (9.5)
Nominal embed. h_{nom}	in. (mm)	1-5/8 (41)	1-5/8 (41)	1-5/8 (41)	1-5/8 (41)	1-5/8 (41)	1-5/8 (41)	1-5/8 (41)	1-5/8 (41)	1-5/8 (41)	1-5/8 (41)	1-5/8 (41)	1-5/8 (41)
Spacing (s)/edge distance (c _s)/concrete thickness (h) - in. (mm)	1-3/4 (44)	n/a	n/a	0.99	1.00	n/a	n/a	0.51	0.62	0.99	1.00	n/a	n/a
	2 (51)	n/a	n/a	1.00		n/a	n/a	0.62	0.76	1.00		n/a	n/a
	2-1/2 (64)	n/a	n/a			n/a	n/a	0.87	1.00			0.78	0.83
	3 (76)	0.92	0.95			0.68	0.71	1.00				0.85	0.91
	3-1/4 (83)	0.96	0.99			0.70	0.73						
	3-1/2 (89)	0.99	1.00			0.71	0.74						
	4 (102)	1.00				0.74	0.78						
	4-1/2 (114)					0.77	0.81						
	5 (127)					0.80	0.85						
	5-1/2 (140)					0.83	0.88						
	6 (152)					0.86	0.92						
	6-1/2 (165)					0.89	0.95						
	7 (178)					0.92	0.98						
7-1/2 (191)					0.95	1.00							
8 (203)					0.98								
9 (229)					1.00								

1 Linear interpolation not permitted.

2 When combining multiple load adjustment factors (e.g. for a 4 anchor pattern in a corner with thin concrete member) the design can become very conservative. To optimize the design, use Hilti PROFIS Engineering software or perform anchor calculation using design equations from ACI 318-14 Chapter 17.

3 Spacing factor reduction in shear, f_{AV} , assumes an influence of a nearby edge. If no edge exists, then $f_{AV} = f_{AN}$.

4 Concrete thickness reduction factor in shear, f_{HV} , assumes an influence of a nearby edge. If no edge exists, then $f_{HV} = 1.0$.

- For concrete thickness greater than or equal to 3-1/4-inches, the anchor can be designed using either table 2 or table 3 of this section.

DESIGN INFORMATION IN CONCRETE PER CSA A23.3

Limit State Design of anchors is described in the provisions of CSA A23.3-14 Annex D for post-installed anchors tested and assessed in accordance with ACI 355.2 for mechanical anchors and ACI 355.4 for adhesive anchors. This section contains the Limit State Design tables with unfactored characteristic loads that are based on the published loads in ICC Evaluation Services ESR-3027. These tables are followed by factored resistance tables. The factored resistance tables have characteristic design loads that are prefactored by the applicable reduction factors for a single anchor with no anchor-to-anchor spacing or edge distance adjustments for the convenience of the user of this document. All the figures in the previous ACI 318-14 Chapter 17 design section are applicable to Limit State Design and the tables will reference these figures.

For a detailed explanation of the tables developed in accordance with CSA A23.3-14 Annex D, refer to Section 3.1.8. Technical assistance is available by contacting Hilti Canada at (800) 363-4458 or at www.hilti.com.

Table 22 - Steel resistance for Hilti KH-EZ, KH-EZ P, KH-EZ PM, KH-EZ PL, KH-EZ C and KH-EZ CRC carbon steel screw anchor^{1,2}



Nominal anchor diameter in.	Nominal embedment in. (mm)			Tensile ³ N _{sar} lb (kN)	Shear ⁴ V _{sar} lb (kN)	Seismic shear ⁵ V _{sar,eq} lb (kN)
1/4	1-5/8 (41)	2-1/2 (64)		3,370 (15.0)	855 (3.8)	770 (3.4)
	1-5/8 (41)	2-1/8 (54)				
3/8	2-1/2 (64)	3-1/4 (83)		6,150 (27.4)	2,865 (12.7)	1,720 (7.7)
	2-1/4 (57)	3 (76)	4-1/4 (108)			
1/2	3-1/4 (83)	4 (102)	5 (127)	14,405 (64.1)	6,200 (27.6)	3,720 (16.5)
3/4	4 (102)		6-1/4 (159)	19,050 (84.7)	9,205 (40.9)	6,385 (28.4)

- 1 See PTG Ed. 19 Section 3.1.8 to convert design strength value to ASD value.
- 2 Hilti KWIK HUS-EZ carbon steel screw anchors are to be considered brittle steel elements.
- 3 Tensile $N_{sar} = A_{se,N} \phi_s f_{uta} R$ as noted in CSA A23.3-14 Annex D.
- 4 Shear determined by static shear tests with $V_{sar} < 0.6 A_{se,V} \phi_s f_{uta} R$ as noted in CSA A23.3-14 Annex D.
- 5 Seismic shear values determined by seismic shear tests with $V_{sar,eq} \leq 0.60 A_{se,V} \phi_s f_{uta} R$ as noted in CSA A23.3-14 Annex D. See PTG Ed. 19 Section 3.1.9 for additional information on seismic applications.

Table 23 - Hilti KH-EZ, KH-EZ P, KH-EZ PM, KH-EZ PL, KH-EZ C and KH-EZ CRC design information in accordance with CSA A23.3-14 Annex D1¹

Design parameter	Symbol	Units	Nominal anchor diameter												Ref A23.3-14		
			1/4		3/8			1/2		5/8			3/4				
Head Style and coating			Hex, P, PM, PL, C head		Hex, C head			Hex head (Including CRC)		Hex head (Including CRC)			Hex head (Including CRC)				
Nominal anchor diameter	d_a	in. (mm)	0.25 (6.4)		0.375 (9.5)			0.5 (12.7)		0.625 (15.9)			0.75 (19.1)				
Effective embedment ²	h_{ef}	in. (mm)	1.18 (30)	1.92 (49)	1.11 (28)	1.54 (39)	1.86 (47)	2.50 (64)	1.52 (39)	2.16 (55)	3.22 (82)	2.39 (61)	3.03 (77)	3.88 (99)	2.92 (74)	4.84 (123)	
Min. nominal embedment ²	h_{nom}	in. (mm)	1-5/8 (41)	2-1/2 (64)	1-5/8 (41)	2-1/8 (54)	2-1/2 (64)	3-1/4 (83)	2-1/4 (57)	3 (76)	4-1/4 (108)	3-1/4 (83)	4 (102)	5 (127)	4 (102)	6-1/4 (159)	
Minimum concrete thickness ³	h_{min}	in. (mm)	3-1/4 (83)	4-1/8 (105)	3-1/4 (83)	3-2/3 (93)	4 (102)	4-3/4 (121)	4-1/2 (114)	4-3/4 (121)	6-3/4 (171)	5 (127)	6 (152)	7 (178)	6 (152)	8-1/8 (206)	
Critical edge distance	c_{ac}	in. (mm)	2 (51)	2.78 (71)	2.63 (67)	2.75 (70)	2.92 (74)	3.75 (95)	2.75 (70)	3.75 (95)	5.25 (133)	3.63 (92)	4.57 (116)	5.82 (148)	4.41 (112)	7.28 (185)	
Minimum spacing at critical edge distance	$s_{min,cac}$	in. (mm)	1.5 (38)		2.25 (57)			3 (76)									
Minimum edge distance	c_{min}	in. (mm)	1.50 (38)						1.75 (44)								
Minimum anchor spacing at minimum edge distance	for $s >$	in. (mm)	3.0 (76)									4 (102)					
Minimum hole depth in concrete	h_0	in. (mm)	2 (51)	2-7/8 (73)	1-7/8 (48)	2-3/8 (60)	2-3/4 (70)	3-1/2 (89)	2-5/8 (67)	3-3/8 (86)	4-5/8 (117)	3-5/8 (92)	4-3/8 (111)	5-3/8 (137)	4-3/8 (111)	6-5/8 (168)	
Minimum specified ultimate strength	f_{uta}	psi (N/mm ²)	125,000 (860)		106,975 (738)			120,300 (830)		112,540 (776)			90,180 (622)		81,600 (563)		
Effective tensile stress area	$A_{se,N}$	in ² (mm ²)	0.045 (29.0)		0.086 (55.5)			0.161 (103.9)		0.268 (172.9)			0.392 (252.9)				
Steel embed. material resistance factor for reinforcement	ϕ_s	-	0.85												8.4.3		
Resistance modification factor for tension, steel failure modes ⁴	R	-	0.70												D.5.3		
Resistance modification factor for shear, steel failure modes ⁴	R	-	0.65												D.5.3		
Factored steel resistance in tension	N_{sar}	lb (kN)	3,370 (15.0)		5,475 (24.4)			6,150 (27.4)		10,780 (48.0)			14,405 (64.1)		19,050 (84.7)		D.6.1.2
Factored steel resistance in shear	V_{sar}	lb (kN)	855 (3.8)		2,030 (9.0)			2,865 (12.7)		5,110 (22.7)			6,200 (27.6)		9,205 (40.9)		D.7.1.2
Factored steel resistance in shear, seismic	$V_{sar,eq}$	lb (kN)	770 (3.4)		2,030 (9.0)			1,720 (7.7)		3,065 (13.6)			3,720 (16.5)		6,385 (28.4)		
Coeff. for factored conc. breakout resistance, uncracked concrete	$k_{c,uncr}$	lb	10						11.25						D.6.2.2		
Coeff. for factored conc. breakout resistance, cracked concrete	$k_{c,cr}$	-	7												D.6.2.2		
Modification factor for anchor resistance, tension, uncracked concrete ⁵	$\psi_{c,N}$	-	1.0												D.6.2.6		
Anchor category	-	-	3		1										D.5.3 (c)		
Concrete material resistance factor	ϕ_c	-	0.65												8.4.2		
Resistance modification factor for tension and shear, concrete failure modes, Condition B ⁶	R	-	0.75		1.00										D.5.3 (c)		
Factored pullout resistance in 20 MPa uncracked concrete ⁷	$N_{pr,uncr}$	lb (kN)	665 (3.0)	1,645 (7.3)	NA												D.6.3.2
Factored pullout resistance in 20 MPa cracked concrete ⁷	$N_{pr,cr}$	lb (kN)	340 (1.5)	815 (3.6)	510 (2.3)	NA										D.6.3.2	
Factored seismic pullout resistance in 20 MPa cracked concrete ⁷	$N_{pr,eq}$	lb (kN)	275 (1.2)	815 (3.6)	510 (2.3)	NA										D.6.3.2	

¹ Design information in this table is taken from ICC-ES ESR-3027, dated February, 2016, tables 2, 3, and 4, and converted for use with CSA A23.3-14 Annex D.

² See Figure 1 on Page 2 of this document.

³ For concrete over metal deck applications where the concrete thickness over the top flute is less than h_{min} in this table, see figure 4 and tables 20 and 21 of this document.

⁴ The KWIK HUS-EZ is considered a brittle steel element as defined by CSA A23.3-14 Annex D section D.2.

⁵ For all design cases, $\psi_{c,N} = 1.0$. The appropriate coefficient for breakout resistance for cracked concrete ($k_{c,cr}$) or uncracked concrete ($k_{c,uncr}$) must be used.

⁶ For use with the load combinations of CSA A23.3-14 chapter 8. Condition B applies where supplementary reinforcement in conformance with CSA A23.3-14 section D.5.3 is not provided, or where pullout or pryout strength governs. For cases where the presence of supplementary reinforcement can be verified, the resistance modification factors associated with Condition A may be used.

⁷ For all design cases, $\psi_{c,p} = 1.0$. NA (not applicable) denotes that this value does not control for design. See section 4.1.4 of ESR-3027 for additional information.



Table 24 - Hilti KH-EZ, KH-EZ P, KH-EZ PM, KH-EZ PL, KH-EZ C and KH-EZ CRC carbon steel screw anchor factored resistance with concrete/pullout failure in uncracked concrete^{1,2,3,4}

Nominal anchor diameter in.	Effective embed. in. (mm)	Nominal embed. in. (mm)	Tension - N_t				Shear - V_r			
			$f'_c = 20$ MPa (2,900psi) lb (kN)	$f'_c = 25$ MPa (3,625 psi) lb (kN)	$f'_c = 30$ MPa (4,350 psi) lb (kN)	$f'_c = 40$ MPa (5,800 psi) lb (kN)	$f'_c = 20$ MPa (2,900 psi) lb (kN)	$f'_c = 25$ MPa (3,625 psi) lb (kN)	$f'_c = 30$ MPa (4,350 psi) lb (kN)	$f'_c = 40$ MPa (5,800 psi) lb (kN)
1/4	1.18 (30)	1-5/8 (41)	665 (3.0)	710 (3.2)	750 (3.3)	820 (3.6)	805 (3.6)	900 (4.0)	985 (4.4)	1,135 (5.1)
	1.92 (49)	2-1/2 (64)	1,645 (7.3)	1,840 (8.2)	2,015 (9.0)	2,325 (10.4)	2,225 (9.9)	2,490 (11.1)	2,725 (12.1)	3,145 (14.0)
3/8	1.11 (28)	1-5/8 (41)	980 (4.4)	1,095 (4.9)	1,200 (5.3)	1,385 (6.2)	980 (4.4)	1,095 (4.9)	1,200 (5.3)	1,385 (6.2)
	1.54 (39)	2-1/8 (54)	1,600 (7.1)	1,785 (8.0)	1,960 (8.7)	2,260 (10.1)	1,600 (7.1)	1,785 (8.0)	1,960 (8.7)	2,260 (10.1)
	1.86 (47)	2-1/2 (64)	2,120 (9.4)	2,375 (10.6)	2,600 (11.6)	3,000 (13.3)	2,120 (9.4)	2,375 (10.6)	2,600 (11.6)	3,000 (13.3)
	2.50 (64)	3-1/4 (83)	3,305 (14.7)	3,695 (16.4)	4,050 (18.0)	4,675 (20.8)	3,305 (14.7)	3,695 (16.4)	4,050 (18.0)	4,675 (20.8)
	1.52 (39)	2-1/4 (57)	1,765 (7.8)	1,970 (8.8)	2,160 (9.6)	2,495 (11.1)	1,765 (7.8)	1,970 (8.8)	2,160 (9.6)	2,495 (11.1)
1/2	2.16 (55)	3 (76)	2,990 (13.3)	3,340 (14.9)	3,660 (16.3)	4,225 (18.8)	2,990 (13.3)	3,340 (14.9)	3,660 (16.3)	4,225 (18.8)
	3.22 (82)	4-1/4 (108)	5,440 (24.2)	6,080 (27.0)	6,660 (29.6)	7,690 (34.2)	10,875 (48.4)	12,160 (54.1)	13,320 (59.3)	15,380 (68.4)
	2.39 (61)	3-1/4 (83)	3,475 (15.5)	3,890 (17.3)	4,260 (18.9)	4,920 (21.9)	3,475 (15.5)	3,890 (17.3)	4,260 (18.9)	4,920 (21.9)
5/8	3.03 (77)	4 (102)	4,985 (22.2)	5,573 (24.8)	6,105 (27.2)	7,049 (31.4)	10,736 (47.8)	12,004 (53.4)	13,149 (58.5)	15,183 (67.5)
	3.88 (99)	5 (127)	7,195 (32.0)	8,040 (35.8)	8,810 (39.2)	10,170 (45.2)	14,385 (64.0)	16,085 (71.5)	17,620 (78.4)	20,345 (90.5)
	2.92 (74)	4 (102)	4,695 (20.9)	5,250 (23.4)	5,750 (25.6)	6,640 (29.5)	9,390 (41.8)	10,500 (46.7)	11,505 (51.2)	13,280 (59.1)
3/4	4.84 (123)	6-1/4 (159)	10,020 (44.6)	11,205 (49.8)	12,275 (54.6)	14,170 (63.0)	20,040 (89.2)	22,410 (99.7)	24,545 (109.2)	28,345 (126.1)

Table 25 - Hilti KH-EZ, KH-EZ P, KH-EZ PM, KH-EZ PL, KH-EZ C and KH-EZ CRC carbon steel screw anchor factored resistance with concrete/pullout failure in cracked concrete^{1,2,3,4,5}



Nominal anchor diameter in.	Effective embed. in. (mm)	Nominal embed. in. (mm)	Tension - N_t				Shear - V_r			
			$f'_c = 20$ MPa (2,900psi) lb (kN)	$f'_c = 25$ MPa (3,625 psi) lb (kN)	$f'_c = 30$ MPa (4,350 psi) lb (kN)	$f'_c = 40$ MPa (5,800 psi) lb (kN)	$f'_c = 20$ MPa (2,900 psi) lb (kN)	$f'_c = 25$ MPa (3,625 psi) lb (kN)	$f'_c = 30$ MPa (4,350 psi) lb (kN)	$f'_c = 40$ MPa (5,800 psi) lb (kN)
1/4	1.18 (30)	1-5/8 (41)	340 (1.5)	360 (1.6)	385 (1.7)	415 (1.9)	565 (2.5)	630 (2.8)	690 (3.1)	795 (3.5)
	1.92 (49)	2-1/2 (64)	815 (3.6)	910 (4.1)	1,000 (4.4)	1,155 (5.1)	1,560 (6.9)	1,740 (7.7)	1,910 (8.5)	2,205 (9.8)
3/8	1.11 (28)	1-5/8 (41)	510 (2.3)	570 (2.5)	620 (2.8)	720 (3.2)	685 (3.0)	765 (3.4)	840 (3.7)	970 (4.3)
	1.54 (39)	2-1/8 (54)	1,120 (5.0)	1,250 (5.6)	1,370 (6.1)	1,585 (7.0)	1,120 (5.0)	1,250 (5.6)	1,370 (6.1)	1,585 (7.0)
	1.86 (47)	2-1/2 (64)	1,485 (6.6)	1,660 (7.4)	1,820 (8.1)	2,100 (9.3)	1,485 (6.6)	1,660 (7.4)	1,820 (8.1)	2,100 (9.3)
	2.50 (64)	3-1/4 (83)	2,315 (10.3)	2,590 (11.5)	2,835 (12.6)	3,275 (14.6)	2,315 (10.3)	2,590 (11.5)	2,835 (12.6)	3,275 (14.6)
	1.52 (39)	2-1/4 (57)	1,095 (4.9)	1,225 (5.5)	1,345 (6.0)	1,550 (6.9)	1,095 (4.9)	1,225 (5.5)	1,345 (6.0)	1,550 (6.9)
1/2	2.16 (55)	3 (76)	1,860 (8.3)	2,080 (9.2)	2,275 (10.1)	2,630 (11.7)	1,860 (8.3)	2,080 (9.2)	2,275 (10.1)	2,630 (11.7)
	3.22 (82)	4-1/4 (108)	3,385 (15.1)	3,785 (16.8)	4,145 (18.4)	4,785 (21.3)	6,765 (30.1)	7,565 (33.7)	8,290 (36.9)	9,570 (42.6)
	2.39 (61)	3-1/4 (83)	2,165 (9.6)	2,420 (10.8)	2,650 (11.8)	3,060 (13.6)	2,165 (9.6)	2,420 (10.8)	2,650 (11.8)	3,060 (13.6)
5/8	3.03 (77)	4 (102)	3,139 (14.0)	3,509 (15.6)	3,844 (17.1)	4,439 (19.7)	6,760 (30.1)	7,558 (33.6)	8,279 (36.8)	9,560 (42.5)
	3.88 (99)	5 (127)	4,475 (19.9)	5,005 (22.3)	5,480 (24.4)	6,330 (28.2)	8,950 (39.8)	10,005 (44.5)	10,965 (48.8)	12,660 (56.3)
	2.92 (74)	4 (102)	2,920 (13.0)	3,265 (14.5)	3,580 (15.9)	4,130 (18.4)	5,845 (26.0)	6,535 (29.1)	7,155 (31.8)	8,265 (36.8)
3/4	4.84 (123)	6-1/4 (159)	6,235 (27.7)	6,970 (31.0)	7,635 (34.0)	8,820 (39.2)	12,470 (55.5)	13,945 (62.0)	15,275 (67.9)	17,635 (78.4)

1 See PTG Ed. 19 Section 3.1.8 to convert factored resistance value to ASD value.
 2 Linear interpolation between embedment depths and concrete compressive strengths is not permitted.
 3 Apply spacing, edge distance, and concrete thickness factors in tables 6 to 15 as necessary. Compare to the steel values in table 22. The lesser of the values is to be used for the design.
 4 Tabular values are for normal-weight concrete only. For lightweight concrete multiply design strength by λ_a as follows: for sand-lightweight, $\lambda_a = 0.68$; for all-lightweight, $\lambda_a = 0.60$
 5 Tabular values are for static loads only. Seismic design is not permitted for uncracked concrete. For seismic tension loads, multiply cracked concrete tabular values in tension by the following reduction factors:
 1/4-in diameter by 1-5/8-in nominal embedment depth - $\alpha_{N,seis} = 0.60$ All other sizes - $\alpha_{N,seis} = 0.75$
 No reduction needed for seismic shear. See PTG Ed. 19 Section 3.1.8 for additional information on seismic applications.

Table 26 - Hilti KH-EZ, KH-EZ P, KH-EZ PM, KH-EZ PL, KH-EZ C and KH-EZ CRC in the soffit of uncracked lightweight concrete over metal deck^{1,2,3,4,5,6}



Nominal anchor diameter in.	Nominal embedment in. (mm)	Installation in lower flute				Installation in upper flute			
		Tension - N_r		Shear - V_r		Tension - N_r		Shear - V_r	
		$f'_c = 20$ MPa (2,900psi) lb (kN)	$f'_c = 30$ MPa (4,350psi) lb (kN)	$f'_c = 20$ MPa (2,900psi) lb (kN)	$f'_c = 30$ MPa (4,350psi) lb (kN)	$f'_c = 20$ MPa (2,900psi) lb (kN)	$f'_c = 30$ MPa (4,350psi) lb (kN)	$f'_c = 20$ MPa (2,900psi) lb (kN)	$f'_c = 30$ MPa (4,350psi) lb (kN)
1/4	1-5/8 (41)	585 (2.6)	660 (2.9)	665 (3.0)	665 (3.0)	720 (3.2)	810 (3.6)	665 (3.0)	665 (3.0)
	2-1/2 (64)	1,200 (5.3)	1,470 (6.5)	1,220 (5.4)	1,220 (5.4)	1,255 (5.6)	1,535 (6.8)	1,805 (8.0)	1,805 (8.0)
3/8	1-5/8 (41)	830 (3.7)	1,020 (4.5)	835 (3.7)	835 (3.7)	950 (4.2)	1,165 (5.2)	2,030 (9.0)	2,030 (9.0)
	2-1/2 (64)	1,430 (6.4)	1,755 (7.8)	835 (3.7)	835 (3.7)	1,865 (8.3)	2,285 (10.2)	3,365 (15.0)	3,365 (15.0)
	3-1/4 (83)	2,505 (11.1)	3,070 (13.7)	1,990 (8.9)	1,990 (8.9)	n/a	n/a	n/a	n/a
1/2	2-1/4 (57)	835 (3.7)	1,020 (4.5)	885 (3.9)	885 (3.9)	890 (4.0)	1,090 (4.8)	4,335 (19.3)	4,335 (19.3)
	3 (76)	1,955 (8.7)	2,395 (10.7)	1,615 (7.2)	1,615 (7.2)	n/a	n/a	n/a	n/a
	4-1/4 (108)	3,425 (15.2)	4,195 (18.7)	1,985 (8.8)	1,985 (8.8)	n/a	n/a	n/a	n/a
5/8	3-1/4 (83)	2,670 (11.9)	3,270 (14.5)	1,915 (8.5)	1,915 (8.5)	n/a	n/a	n/a	n/a
	5 (127)	6,070 (27.0)	7,430 (33.1)	2,315 (10.3)	2,315 (10.3)	n/a	n/a	n/a	n/a
3/4	4 (102)	2,670 (11.9)	3,270 (14.5)	2,075 (9.2)	2,075 (9.2)	n/a	n/a	n/a	n/a

Table 27 - Hilti KH-EZ, KH-EZ P, KH-EZ PM, KH-EZ PL, KH-EZ C and KH-EZ CRC in the soffit of cracked lightweight concrete over metal deck^{1,2,3,4,5,6}



Nominal anchor diameter in.	Nominal embedment in. (mm)	Installation in lower flute				Installation in upper flute			
		Tension - N_r^7		Shear - V_r^8		Tension - N_r^7		Shear - V_r^8	
		$f'_c = 20$ MPa (2,900psi) lb (kN)	$f'_c = 30$ MPa (4,350psi) lb (kN)	$f'_c = 20$ MPa (2,900psi) lb (kN)	$f'_c = 30$ MPa (4,350psi) lb (kN)	$f'_c = 20$ MPa (2,900psi) lb (kN)	$f'_c = 30$ MPa (4,350psi) lb (kN)	$f'_c = 20$ MPa (2,900psi) lb (kN)	$f'_c = 30$ MPa (4,350psi) lb (kN)
1/4	1-5/8 (41)	300 (1.3)	340 (1.5)	665 (3.0)	665 (3.0)	365 (1.6)	445 (2.0)	665 (3.0)	665 (3.0)
	2-1/2 (64)	595 (2.6)	730 (3.2)	1,220 (5.4)	1,220 (5.4)	625 (2.8)	765 (3.4)	1,805 (8.0)	1,805 (8.0)
3/8	1-5/8 (41)	520 (2.3)	635 (2.8)	835 (3.7)	835 (3.7)	755 (3.4)	930 (4.1)	2,030 (9.0)	2,030 (9.0)
	2-1/2 (64)	1,015 (4.5)	1,245 (5.5)	835 (3.7)	835 (3.7)	1,325 (5.9)	1,620 (7.2)	3,365 (15.0)	3,365 (15.0)
	3-1/4 (83)	1,775 (7.9)	2,175 (9.7)	1,990 (8.9)	1,990 (8.9)	n/a	n/a	n/a	n/a
1/2	2-1/4 (57)	525 (2.3)	640 (2.8)	885 (3.9)	885 (3.9)	630 (2.8)	770 (3.4)	4,335 (19.3)	4,335 (19.3)
	3 (76)	1,235 (5.5)	1,510 (6.7)	1,615 (7.2)	1,615 (7.2)	n/a	n/a	n/a	n/a
	4-1/4 (108)	2,155 (9.6)	2,640 (11.7)	1,985 (8.8)	1,985 (8.8)	n/a	n/a	n/a	n/a
5/8	3-1/4 (83)	1,680 (7.5)	2,060 (9.2)	1,915 (8.5)	1,915 (8.5)	n/a	n/a	n/a	n/a
	5 (127)	3,820 (17.0)	4,680 (20.8)	2,315 (10.3)	2,315 (10.3)	n/a	n/a	n/a	n/a
3/4	4 (102)	1,680 (7.5)	2,060 (9.2)	2,075 (9.2)	2,075 (9.2)	n/a	n/a	n/a	n/a

- See PTG Ed. 19 Section 3.1.8 to convert design strength value to ASD value.
- Linear interpolation between embedment depths and concrete compressive strengths is not permitted.
- Tabular value is for one anchor per flute. Minimum spacing along the length of the flute is $3 \times h_{nom}$ (nominal embedment).
- Tabular values are lightweight concrete and no additional reduction factor is needed.
- No additional reduction factors for spacing or edge distance need to be applied.
- Comparison of the tabular values to the steel strength is not necessary. Tabular values control.
- Tabular values are for static loads only. Seismic design is not permitted for uncracked concrete. For seismic tension loads, multiply cracked concrete tabular values in tension by the following reduction factors:
 1/4-in diameter by 1-5/8-in nominal embedment depth - $\alpha_{N,seis} = 0.60$
 All other sizes - $\alpha_{N,seis} = 0.75$.
 See PTG Ed. 19 Section 3.1.8 for additional information on seismic applications.
- For the following anchor sizes, an additional factor for seismic shear must be applied to the cracked concrete tabular values for seismic conditions:
 1/4-inch diameter - $\alpha_{V,seis} = 0.75$
 3/8-inch diameter - $\alpha_{V,seis} = 0.60$
 1/2-inch diameter - $\alpha_{V,seis} = 0.60$
 5/8-inch diameter - $\alpha_{V,seis} = 0.60$
 3/4-inch diameter - $\alpha_{V,seis} = 0.70$

Table 28 - Hilti KH-EZ, KH-EZ P, KH-EZ PM, KH-EZ PL, KH-EZ C and KH-EZ CRC steel screw anchor factored resistance in the top of uncracked concrete over metal deck^{1,2,3,4,5}



Nominal anchor diameter in.	Effective embed. in. (mm)	Nominal embed. in. (mm)	Tension - N_r		Shear - V_r	
			$f'_c = 20$ MPa (2,900psi) lb (kN)	$f'_c = 30$ MPa (4,350 psi) lb (kN)	$f'_c = 20$ MPa (2,900 psi) lb (kN)	$f'_c = 30$ MPa (4,350 psi) lb (kN)
1/4	1.18 (30)	1-5/8 (41)	665 (3.0)	750 (3.3)	805 (3.6)	985 (4.4)
3/8	1.11 (28)	1-5/8 (41)	980 (4.4)	1,200 (5.3)	980 (4.4)	1,200 (5.3)

Table 29 - Hilti KH-EZ, KH-EZ P, KH-EZ PM, KH-EZ PL, KH-EZ C and KH-EZ CRC steel anchor factored resistance in the top of cracked concrete over metal deck^{1,2,3,4,5}



Nominal anchor diameter in.	Effective embed. in. (mm)	Nominal embed. in. (mm)	Tension - N_r		Shear - V_r	
			$f'_c = 20$ MPa (2,900psi) lb (kN)	$f'_c = 30$ MPa (4,350 psi) lb (kN)	$f'_c = 20$ MPa (2,900 psi) lb (kN)	$f'_c = 30$ MPa (4,350 psi) lb (kN)
1/4	1.18 (30)	1-5/8 (41)	340 (1.5)	385 (1.7)	565 (2.5)	690 (3.1)
3/8	1.11 (28)	1-5/8 (41)	510 (2.3)	620 (2.8)	685 (3.0)	840 (3.7)

- 1 See PTG Ed. 19 Section 3.1.8 to convert design strength value to ASD value.
- 2 Linear interpolation between embedment depths and concrete compressive strengths is not permitted.
- 3 Apply spacing, edge distance, and concrete thickness factors in tables 20 and 21 as necessary. Compare to the steel values in table 22. The lesser of the values is to be used for the design.
- 4 Tabular values are for normal-weight concrete only. For lightweight concrete multiply design strength by λ_a as follows:
for sand-lightweight, $\lambda_a = 0.68$; for all-lightweight, $\lambda_a = 0.60$
- 5 Tabular values are for static loads only. Seismic design is not permitted for uncracked concrete. For seismic tension loads, multiply cracked concrete tabular values in tension by the following reduction factors:
1/4-inch diameter - $\alpha_{N,seis} = 0.60$
3/8-inch diameter - $\alpha_{N,seis} = 0.75$.
No reduction needed for seismic shear. See PTG Ed. 19 Section 3.1.8 for additional information on seismic applications.

DESIGN INFORMATION IN MASONRY

Table 30 – Allowable tension loads for Hilti KH-EZ, KH-EZ P, KH-EZ PM, KH-EZ PL, KH-EZ C and KH-EZ CRC installed in grout-filled masonry walls (lb)^{1,2,3,4,5}

Nominal anchor diameter in.	Embedment in. ⁶	Loads @ c _{cr} and s _{cr}	Spacing			Edge distance
			Critical - s _{cr} in. ⁷	Minimum - s _{min} in. ⁷	Load reduction factor at s _{min} ⁸	Critical - c _{cr} Minimum - c _{min} in. ⁹
1/4	1-5/8	530 ¹⁰	4	2	0.70	4
	2-1/2	910 ¹¹		4	1.00	
3/8	1-5/8	535 ¹¹	4	2	0.70	4
	2-1/2	895	6	4	0.80	
	3-1/4	1,210				
1/2	2-1/4	710	4	2	0.60	4
	3	1,110	8	4		
	4-1/4	1,515				
5/8	3-1/4	1,155	10	4	0.60	4
	5	1,735				
3/4	4	1,680	12	4	0.60	4
	6-1/4	2,035				

Table 31 – Allowable shear loads for Hilti KH-EZ, KH-EZ P, KH-EZ PM, KH-EZ PL, KH-EZ C and KH-EZ CRC installed in grout-filled masonry walls (lb)^{1,2,3,4,5}

Nominal anchor diameter in.	Embedment in. ⁶	Load at c _{cr} and s _{cr}	Spacing			Edge distance			
			Critical - s _{cr} in. ⁷	Minimum - s _{min} in. ⁷	Load reduction factor at s _{min} ⁸	Critical - c _{cr} in. ⁹	Minimum - c _{min} in. ⁹	Load reduction factor at c _{min}	
								perpendicular to edge	parallel to edge
1/4	1-5/8	675 ¹⁰	4	4	1.00	4	4	1.00	1.00
	2-1/2	840 ¹¹						1.00	1.00
3/8	1-5/8	1,140 ¹¹	6	4	0.94	6	4	0.61	1.00
	2-1/2	1,165						0.70	1.00
	3-1/4	1,190						0.70	1.00
	2-1/4	1,845						0.50	1.00
1/2	3	2,055	8	4	0.88	8	4	0.45	0.94
	4-1/4	2,745						0.40	0.89
	3-1/4	3,040						0.36	0.82
5/8	5	3,485	10	4	0.36	10	4	0.34	0.92
	4	3,040						0.36	0.82
3/4	6-1/4	3,485	10	4	0.36	10	4	0.34	0.92

1 All values are for anchors installed in fully grouted masonry with minimum masonry prism strength of 1,500 psi. Concrete masonry units may be lightweight, medium-weight or normal-weight.

2 Anchors may not be installed within one inch in any direction of a vertical joint.

3 Linear interpolation of load values between minimum spacing s_{min} and critical spacing s_{cr} and between minimum edge distance c_{min} and critical edge distance c_{cr} is permitted.

4 For combined loading: For 1/4-in. - $\frac{T_{\text{applied}}}{T_{\text{allowable}}} + \frac{V_{\text{applied}}}{V_{\text{allowable}}} \leq 1$ For 3/8- through 3/4-in. - $\left(\frac{T_{\text{applied}}}{T_{\text{allowable}}}\right)^{5/3} + \left(\frac{V_{\text{applied}}}{V_{\text{allowable}}}\right)^{5/3} \leq 1$

5 See Figure 5 on Page 21 of this document for anchor locations for anchor locations.

6 Embedment depth is measured from the outside face of the concrete masonry embedment.

7 Critical spacing s_{cr} is the anchor spacing where full load values may be used. The minimum spacing s_{min} is the minimum spacing for which values are available and installation is recommended. Spacing is measured from the center of one anchor to the center of the adjacent anchor.

8 Load reduction factors are multiplicative, both spacing and edge distance load reduction factors must be considered. Load values for anchors installed at less than c_{cr} or s_{cr} must be multiplied by the appropriate load reduction factor based on actual edge distance (c) or spacing (s).

9 The critical edge distance c_{cr} is the edge distance where full load values may be used. The minimum edge distance c_{min} is the minimum edge distance for which values are available and installation is recommended. For tension, c_{cr} equals c_{min}. Edge distance is measured from the center of the anchor to the closest edge.

10 Load values must be reduced by 21% for installations within 1-1/4 inches of the bed joint.

11 Load values must be reduced by 13% for installations within 1-1/4 inches of the bed joint.

Table 32 – Hilti KH-EZ, KH-EZ P, KH-EZ PM, KH-EZ PL, KH-EZ C and KH-EZ CRC allowable loads installed in top-of-grout-filled concrete masonry walls or horizontal members of wall openings^{1,2,3}

Nominal anchor diameter in.	Minimum embedment depth in.	Edge distance ⁴ in.	Critical spacing ⁵ in.	Minimum end distance ⁶ in.	Tension lb	Shear lb	
						Load direction	
						Parallel to edge of masonry wall	Perpendicular to edge of masonry wall
1/4	1 5/8	1 1/2	4	4	205	180	135
		3 3/4			205	275	275
	2 1/2	1 1/2			355	345	155
		3 3/4			390	415	330
3/8	1 5/8	1 1/2	6	6	245	345	175
		3 3/4			245	345	345
	3 1/4	1 1/2			465	490	200
		3 3/4			540	800	625
1/2	2 1/4	1 3/4	8	8	390	460	200
		3 3/4			610	525	500
	4 1/4	1 3/4			540	885	245
		3 3/4			750	1275	550
5/8	5	1 3/4	10	10	975	930	245
		3 3/4			975	2190	630
3/4	6 1/4	3 3/4	12	12	975	2430	630

Table 33 – Hilti KH-EZ, KH-EZ P, KH-EZ PM, KH-EZ PL, KH-EZ C and KH-EZ CRC allowable loads installed in end-of-wall or vertical members of wall openings^{1,2}

Nominal anchor diameter in.	Minimum embedment depth in.	Edge distance ⁴ in.	Critical spacing ⁵ in.	Minimum end distance ⁶ in.	Tension lb	Shear lb	
						Load direction	
						Parallel to edge of masonry wall	Perpendicular to edge of masonry wall
1/4	1 5/8	1 1/2	4	4	360	525	205
		3 3/4			380	595	585
	2 1/2	1 1/2			590	610	225
		3 3/4			755	635	585
3/8	1 5/8	1 1/2	6	6	355	725	215
		3 3/4			465	1010	825
	3 1/4	1 1/2			565	875	240
		3 3/4			1020	1195	1050
1/2	2 1/4	1 3/4	8	8	500	855	280
		3 3/4			525	1100	1050
	4 1/4	1 3/4			650	925	280
		3 3/4			1150	1240	1050
5/8	5	3 3/4	10	10	1605	2215	1050
3/4	6 1/4	3 3/4	12	12	1865	2550	1050

- 1 All values are for anchors installed in fully grouted concrete masonry with minimum masonry prism strength of 1,500 psi. Concrete masonry units may be lightweight, medium-weight or normal-weight conforming to ASTM C90. Allowable loads are calculated using safety factor of 5.
- 2 See figure 6 and 7 for allowable anchor installation locations on the top of grout-filled concrete masonry walls. Anchors may not be installed within one inch of a vertical joint. See figure 7 for anchor installation locations in end-of-wall and vertical members of wall openings.
- 3 Anchors may not be installed within 1-1/4" in any direction of a head joint.
- 4 For load values at edge distances between listed values linear interpolation is permitted.
- 5 Critical spacing equals minimum spacing.
- 6 Minimum end distance applicable to top-of-wall and end-of-wall and does not apply for wall openings such as windows.

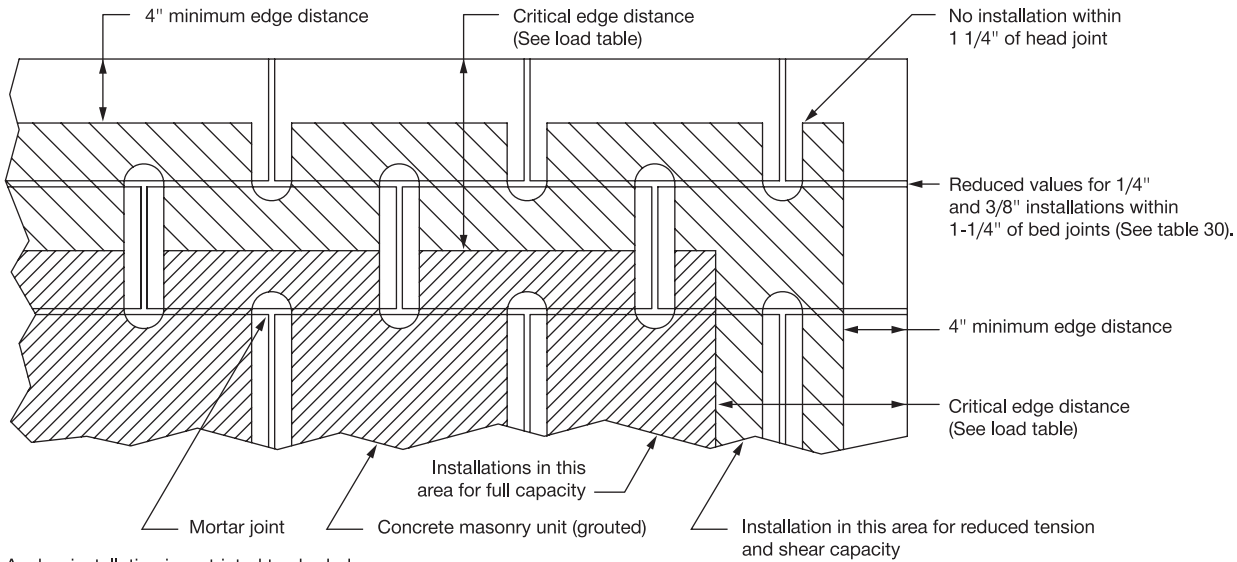

Anchor installation is restricted to shaded areas

Figure 5 – Acceptable locations (shaded areas) for Hilti KH-EZ, KH-EZ P, KH-EZ PM, KH-EZ PL, KH-EZ C and KH-EZ CRC anchors in grout-filled concrete masonry

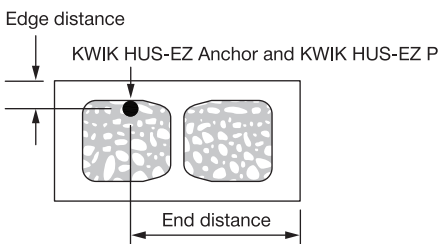

Figure 6 – Edge and end distances for the Hilti KH-EZ, KH-EZ P, KH-EZ PM, KH-EZ PL, KH-EZ C and KH-EZ CRC anchor installed in the top of CMU masonry wall construction

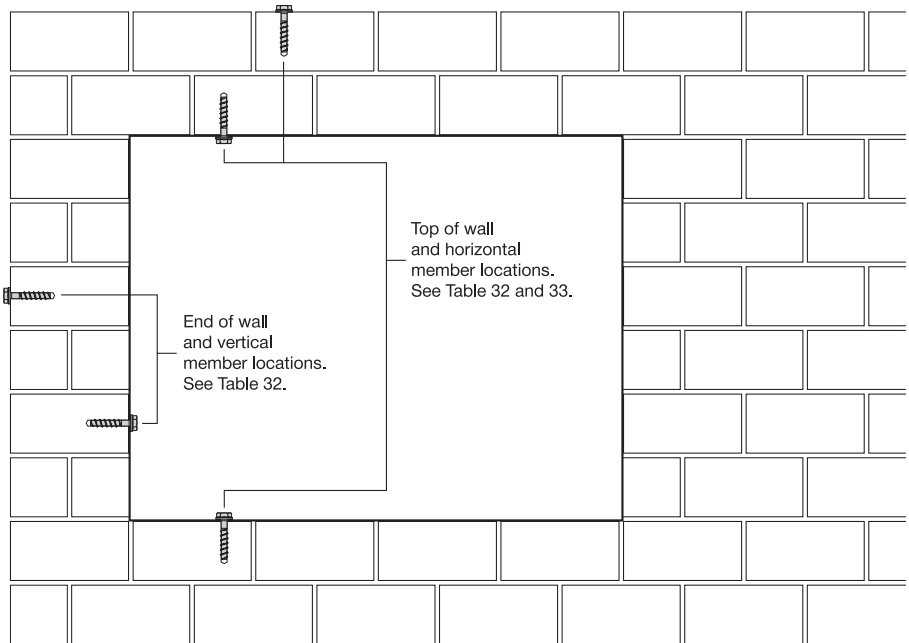

Figure 7 – Anchor locations in end of wall or wall opening applications

DESIGN INFORMATION IN HOLLOW CORE CONCRETE PER ALLOWABLE STRESS DESIGN

Table 34 - Hilti KH-EZ, KH-EZ P, KH-EZ PM, KH-EZ PL, KH-EZ C and KH-EZ CRC allowable stress design values for installations into hollow core concrete panels^{1,2}

Anchor diameter (inches)	Min. effective embedment h_{ef} (inches)	Allowable load ³		Ultimate load	
		Tension	Shear	Tension	Shear
1/4	1-1/8	400	610	1600	2440
	1-3/8	455	755	1810	3025
3/8	1-1/8	435	890	1740	3560

- 1 The admissible anchor location must be established to prevent damage to the prestressed cable during the drilling process. Verify the location and height of the cable with the hollow core plank supplier to confirm admissible anchor location.
- 2 Minimum compressive strength of prestressed concrete is 7,000 psi. Published ultimate loads represent the average results conducted in local base materials. Due to variations in materials and dimensional configurations, on-site testing is required to determine the actual performance.
- 3 Allowable loads calculated with a factor of safety of 4.

Figure 8 - Installation of Hilti KH-EZ, KH-EZ P, KH-EZ PM, KH-EZ PL, KH-EZ C and KH-EZ CRC in hollow core concrete

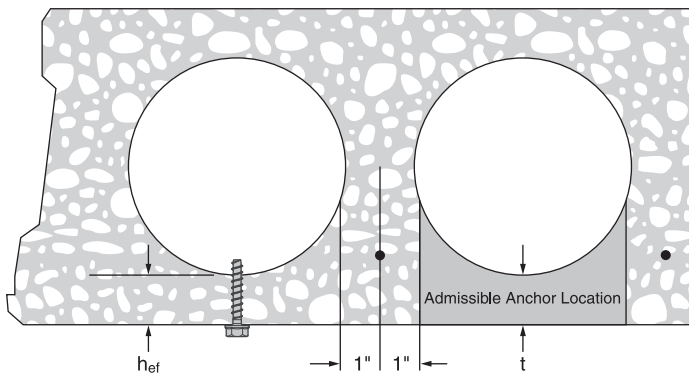

INSTALLATION INSTRUCTIONS

Installation Instructions For Use (IFU) are included with each product package. They can also be viewed or downloaded online at www.hilti.com. Because of the possibility of changes, always verify that downloaded IFU are current when used. Proper installation is critical to achieve full performance. Training is available on request. Contact Hilti Technical Services for applications and conditions not addressed in the IFU.

ORDERING INFORMATION



Order Information

Description	Hole Diameter	Total Length without Anchor Head	Screw Anchor Head Height (in)	Screw Anchor Head Width (in)	Minimum Embedment Depth	Qty (pcs) / Box
KH-EZ P 1/4"x1 7/8"	1/4"	1 7/8	0.13	0.52	1 5/8	100
KH-EZ P 1/4"x2 5/8"	1/4"	2 5/8	0.13	0.52	1 5/8	100
KH-EZ PM 1/4"x2 5/8"	1/4"	2 5/8	0.13	0.69	1 5/8	100
KH-EZ PM 1/4"x1 7/8"	1/4"	1 7/8	0.13	0.69	1 5/8	100
KH-EZ PL 1/4"x2 5/8"	1/4"	2 5/8	0.18	0.86	1 5/8	100
KH-EZ C 1/4"x2"	1/4"	2	0.16	0.45	1 5/8	100
KH-EZ C 1/4"x2 1/2"	1/4"	2 1/2	0.16	0.45	1 5/8	100
KH-EZ C 1/4"x3"	1/4"	3	0.16	0.45	1 5/8	100
KH-EZ C 1/4"x4"	1/4"	4	0.16	0.45	1 5/8	100
KH-EZ 1/4"x1 7/8"	1/4"	1 7/8	0.24	0.44	1 5/8	100
KH-EZ 1/4"x2 5/8"	1/4"	2 5/8	0.24	0.44	1 5/8	100
KH-EZ 1/4"x3"	1/4"	3	0.24	0.44	1 5/8	100
KH-EZ 1/4"x3 1/2"	1/4"	3 1/2	0.24	0.44	1 5/8	100
KH-EZ 1/4"x4"	1/4"	4	0.24	0.44	1 5/8	100
KH-EZ 3/8"x1 7/8"	3/8"	1 7/8	0.35	0.56	1 5/8	50
KH-EZ 3/8"x2 1/8"	3/8"	2 1/8	0.35	0.56	1 5/8	50
KH-EZ (CRC) 3/8"x3"	3/8"	3	0.35	0.56	2 1/2	50
KH-EZ 3/8"x3 1/2"	3/8"	3 1/2	0.35	0.56	2 1/2	50
KH-EZ (CRC) 3/8"x4"	3/8"	4	0.35	0.56	3 1/4	50
KH-EZ (CRC) 3/8"x5"	3/8"	5	0.35	0.56	3 1/4	50
KH-EZ C 3/8"x2 1/2"	3/8"	2 1/2	0.25	0.71	1 5/8	50
KH-EZ C 3/8"x3"	3/8"	3	0.25	0.71	2 1/2	50
KH-EZ C 3/8"x4"	3/8"	4	0.25	0.71	2 1/2	50
KH-EZ 1/2"x2 1/2"	1/2"	2 1/2	0.48	0.75	2 1/4	25
KH-EZ (CRC) 1/2"x3"	1/2"	3	0.48	0.75	2 1/4	25
KH-EZ 1/2"x3 1/2"	1/2"	3 1/2	0.48	0.75	2 1/4	25
KH-EZ (CRC) 1/2"x4"	1/2"	4	0.48	0.75	2 1/4	25
KH-EZ 1/2"x4 1/2"	1/2"	4 1/2	0.48	0.75	3	25
KH-EZ (CRC) 1/2"x5"	1/2"	5	0.48	0.75	3	25
KH-EZ (CRC) 1/2"x6"	1/2"	6	0.48	0.75	3	25
KH-EZ 5/8"x3 1/2"	5/8"	3 1/2	0.57	0.94	3 1/4	15
KH-EZ 5/8"x4"	5/8"	4	0.57	0.94	3 1/4	15
KH-EZ (CRC) 5/8"x5 1/2"	5/8"	5 1/2	0.57	0.94	3 1/4	15
KH-EZ (CRC) 5/8"x6 1/2"	5/8"	6 1/2	0.57	0.94	3 1/4	15
KH-EZ (CRC) 5/8"x8"	5/8"	8	0.57	0.94	3 1/4	15
KH-EZ 3/4"x4 1/2"	3/4"	4 1/2	0.70	1.13	4	10
KH-EZ (CRC) 3/4"x5 1/2"	3/4"	5 1/2	0.70	1.13	4	10
KH-EZ (CRC) 3/4"x7"	3/4"	7	0.70	1.13	4	10
KH-EZ 3/4"x8"	3/4"	8	0.70	1.13	4	10
KH-EZ (CRC) 3/4"x9"	3/4"	9	0.70	1.13	4	10



Hilti, Inc. (U.S.) 1-800-879-8000
en español 1-800-879-5000
www.hilti.com

Hilti (Canada) Corporation 1-800-363-4458
www.hilti.com